



The Pilot's Manual

Instrument Rating Syllabus

Fourth Edition

A Flight & Ground Training Course for
the Instrument Rating based on
**The Pilot's Manual: Instrument Flying
Meets Part 61 and 141 Requirements**



The Pilot's Manual

Instrument Rating Syllabus

Fourth Edition

A Flight & Ground Training Course for
the Instrument Rating based on

**The Pilot's Manual: Instrument Flying
Meets Part 61 and 141 Requirements**

by Jackie Spanitz

**Includes Appendix for
using a Basic ATD as a
loggable training device.**



Aviation Supplies & Academics, Inc.
Newcastle, Washington

The Pilot's Manual: Instrument Rating Syllabus
Fourth Edition
by Jackie Spanitz

©1995–2010 Aviation Supplies & Academics, Inc.
All rights reserved. Fourth Edition published 2010.

Aviation Supplies & Academics, Inc.
7005 132nd Place SE
Newcastle, Washington 98059-3153
425.235.1500
Internet: www.asa2fly.com
Email: asa@asa2fly.com

Printed in the United States of America

2014 2013 2012 2011 2010 9 8 7 6 5 4 3 2 1

ASA-PM-S-14

ISBN 1-56027-886-2
978-1-56027-886-3

03

Contents

	About this Syllabus.....	v
	Compliance Table.....	vii
	Enrollment/Graduation Certificates.....	ix
Stage 1	Instrument Flight	1
	Module 1.....	3
	Module 2.....	4
	Module 3.....	5
	Module 4.....	6
	Module 5.....	7
	Optional Review	8
Stage 2	Navigation	9
	Module 1.....	11
	Module 2.....	12
	Module 3.....	13
	Module 4.....	14
	Module 5.....	15
	Optional Review	16
Stage 3	Holding Procedures	17
	Module 1.....	19
	Module 2.....	20
	Module 3.....	21
	Module 4.....	22
	Module 5.....	23
	Optional Review	24
Stage 4	Instrument Approaches	25
	Module 1.....	27
	Module 2.....	28
	Module 3.....	29
	Module 4.....	30
	Module 5.....	31
	Optional Review	32
Stage 5	En Route & Prep for Checkride	33
	Module 1.....	35
	Module 2.....	36
	Module 3.....	37
	Module 4.....	38
	Module 5.....	39
	Optional Review	40
	Instrument Rating Endorsements and Checkride List	41
	Airman Certificate Application FAA Form 8710-1	43
Appendices	Stage Exams 1–5.....	Appendix 1–1 through 5–8
	Basic ATD Syllabus.....	Appendix 6–1 through 6–10

About This Syllabus

Course Objective:

The objective of this syllabus is for the student to gain the necessary aeronautical skill, knowledge and experience to meet the requirements of an Instrument Rating with an Airplane category and a Single-Engine Land class rating.

Prerequisites:

The student must be able to read, speak, write, and understand the English language, meet the physical standards for a third-class medical certificate, and possess either a Private Pilot or Commercial Pilot certificate with an Airplane category and Single-Engine Land class rating.

Experience Requirements for an Instrument Rating Include:

35 hours of instrument experience for Part 141 (40 hours for Part 61 programs, 15 hours of which must be with an Instrument Instructor)

50 hours cross-country PIC (Part 61 programs)

30 hours of ground training (no minimum time is specified for Part 61 programs)

Instrument Rating Course:

The Instrument Rating is made up of 2 requirements: Aeronautical Skill and Aeronautical Knowledge. This syllabus is written to satisfy 14 CFR Part 141 requirements. With the addition of 5 instrument training flight hours and 50 hours cross-country PIC experience, this syllabus will be equally effective for 14 CFR Part 61 programs. The syllabus is organized into five Stages, with five Modules in each Stage. Each stage must be completed in ____ days, not to be more than 90 days. Each Module contains both a flight and ground lesson. This presents an integrated flight training process and will promote easier learning and a more efficient flight training program. Ideally, the ground lesson will be completed prior to the flight.

Testing Procedures:

Each module contains a reading assignment associated with the ground training program. The review questions following each chapter will test the student's understanding of the material covered throughout the ground lesson, and must be answered prior to moving on to the next module. A Stage Exam is included with each stage, testing the student on both the ground and flight training material covered throughout the stage. This exam must be passed with a minimum score of 80%, and reconciled to 100%, in order to proceed to the next Stage.

It is essential that the objective of each module be accomplished before moving on to the next module.

Minimum Requirements:

The time necessary for the syllabus to qualify for Part 141 operations includes meeting 35 hours of instruction experience (40 hours for Part 61 programs, 15 of which must be with an Instrument Instructor), and 30 hours of ground instruction. This is a *minimum* time—many factors play into the finishing flight time: frequency of flying, cooperative weather, airplane and instructor scheduling, and lapses in the flight training process. It is recommended the student fly at least twice a week. This type of schedule produces the most efficient training, and cuts down on review time. If there is a lapse in between flights, it may be necessary to review maneuvers; use the optional review flights accompanying each Stage for this purpose (this will allow the student to continue following the syllabus, which is necessary for a 141 program). Students are also encouraged to maintain training proficiency with a Basic Aviation Training Device (BATD). See Appendix 6 for details on integrating this technology into the training curriculum. The student should feel comfortable performing each task in all previous modules before progressing to the next stage. If student exceeds more than ____ hours of the minimum 141 recommended time allotted per module, the chief flight instructor must be informed.

Note: Although there is no requirement for instrument solo flight, it is suggested the student perform IFR procedures with a safety pilot for additional practice. See 14 CFR § 91.109 for Safety Pilot requirements.

Basic ATDs

The Federal Aviation Administration has formally recognized the potential of computer-based training devices for use in general aviation instrument flight training curricula. A qualified Basic Aviation Training Device (BATD) is highly beneficial when used under the guidance of an authorized instructor to obtain the aeronautical knowledge and skills required for an instrument rating. See Appendix 6 for details on implementing Basic ATDs into an integrated flight and ground training instrument curriculum.

Although federal aviation regulations require only 35 hours of instrument flight training for an instrument rating, the national average training time is closer to 65 hours. Basic ATDs are superb instructional tools, taking the teaching process out of a hostile environment (the training airplane) and putting it on the computer. All aspects of the training curriculum should be taught to some performance level on the ground before demonstrating competence in the airplane. This positive transfer of learning will greatly reduce the flying hours spent working on earning the instrument rating.

Required Materials for the Instrument Rating Course:

- *Instrument Flying* (#ASA-PM-3)

Recommended Materials for the Instrument Rating Course:

- FAA Instrument Practical Test Standards (referred to as PTS) (#ASA-8081-4)
- ASA FAR/AIM (#ASA-FR-AM-BK, updated annually)
- ASA *Instrument Rating Test Prep* book (#ASA-TP-I), Prepware software (#ASA-TW-I), or Virtual Test Prep DVD Ground School (#ASA-VTP-I)
- ASA *Instrument Oral Exam Guide* (#ASA-OEG-I)
- ASA Flight computer (E6-B or CX-2 Pathfinder)
- ASA Instrument Plotter (#ASA-CP-IFR)
- View limiting device such as Jiffyhood (#ASA-H2G), Hoodwink (#ASA-HOODWINK), or Overcasters (#ASA-OVC)
- ASA Flightlogs for cross-country flights (#ASA-FP-2)
- Low Altitude Enroute Chart for local area
- Sectional for local area
- Airport/Facility Directory for local area
- ASA On Top Basic ATD (#ASA-BATD)

The syllabus uses *The Pilot's Manual: Instrument Flying* for the ground training program. The review following each chapter should be finished with the assigned reading. This text contains an index which will help pinpoint the material for the subject you are working on. ASA's *Instrument Rating Test Prep* is recommended to enhance the program. The prep will ensure the student is completely prepared for the FAA Knowledge Exam upon completion of the course. Instructors using this syllabus must ensure current Practical Test Standards are upheld and the procedures outlined in the *Instrument Flying Handbook* (FAA-H-8083-15) are maintained at all times.

If you have any comments or questions on how to best use this syllabus, please call ASA at 1-800-ASA-2-FLY. We will be happy to provide suggestions on how to tailor this syllabus to specifically meet your training needs. Note to Instructors: Answers to the Stage Exams are available to instructors by calling 1-800-ASA-2-FLY, or you can fax your request on letterhead to 1-425-235-0128.

Part 141 Registration—Instrument Rating

Visit www.asa2fly.com/register to register your Part 141 program using this curriculum and ASA will help you stay current with industry and regulatory changes which may affect your Part 141 curriculum.

Instrument Rating Minimum Course Hours

For Part 141, Appendix C Compliance

These times are for student/instructor guidance only. They are a suggested time schedule which will ensure minimum flight and ground training compliance with 14 CFR Part 141. To follow a Part 61 curriculum, add 5 hours of instrument training, for a total of 40 hours. Also, Part 61 instrument rating applicants are required to have 50 hours cross-country PIC time.

Note: Ground Instruction should include classroom discussion, and pre- and post-flight briefings.

The stage exams may not be credited for more than 5 hours of the 30 hours of required ground training, and the stage checks may not be credited for more than 5 hours of the required 35 hours of flight training.

Page		Ground Instruction	Dual Instrument Flight	Dual Instrument Cross-Country	Done ✓
01	Stage 1				
03	Module 1	1.5	1.5		
04	Module 2	1.0	1.0		
05	Module 3	1.0	1.0		
06	Module 4	1.0	1.0		
07	Module 5	1.5 + Stage Exam	1.5 + Stage Check		
08	* Review	1.5	1.5		
09	Stage 2				
11	Module 1	1.5	1.5		
12	Module 2	1.0	1.0		
13	Module 3	1.0	1.0		
14	Module 4	1.0	1.0		
15	Module 5	1.5 + Stage Exam	1.5 + Stage Check		
16	* Review	1.5	1.5		
17	Stage 3				
19	Module 1	1.5	1.5		
20	Module 2	1.0	1.0		
21	Module 3	1.0	1.0		
22	Module 4	1.0	1.0		
23	Module 5	1.5 + Stage Exam	1.5 + Stage Check		
24	* Review	1.5	1.5		
25	Stage 4				
27	Module 1	1.5	1.5		
28	Module 2	1.0	1.0		
29	Module 3	1.0	1.0		
30	Module 4	1.5	1.5		
31	Module 5	1.5 + Stage Exam	1.5 + Stage Check		
32	* Review	1.5	1.5		
33	Stage 5				
35	Module 1	1.5	2.0	2.0	
36	Module 2	1.0	2.0	2.0	
37	Module 3	1.5	3.5	3.5	
38	Module 4	1.0	1.5		
39	Module 5	1.5 + Stage Exam	1.5 + Stage Check		
40	* Review	1.5	1.5		
	TOTALS	30.0 + Stage Exams	35.0 + Stage Checks	7.5	
* Reviews are not necessary to meet Part 141 compliance, and are not counted in the TOTALS for the program. They are optional, and should be used if the student is not ready to move on to the next module.					

Enrollment Certificate

This is to certify that

Student Name

is enrolled in the Federal Aviation Administration approved
Instrument Rating Course, conducted by

School and Certificate Number

Chief Instructor

Date of Enrollment

Graduation Certificate

This is to certify that

Pilot Name and Number

has satisfactorily completed each required stage of the approved
course of training including the tests for those stages, and has
received _____ hours of cross-country training.

_____ has graduated from the
Federal Aviation Administration approved **Instrument Rating
Course** conducted by

School and Certificate Number

Chief Instructor

Date of Graduation

Stage 1

Instrument Flight

Objective

The objective of Stage 1 is for the student to become proficient in, and have an understanding of the following:



Ground Training

- Course objective
- School requirements, procedures, regulations
- Grading criteria
- Instrument scan techniques
- IFR Instruments
- Straight-and-level flight
- Straight climb and descent
- Turning
- Unusual flight attitudes
- Normal instrument flight on a partial panel
- Training maneuvers used for instrument flight



Flight Training

- Flight training process
- Training airplane
- Instrument preflight
- Aircraft systems related to IFR operations
- Instrument cockpit check
- Flight by reference to instruments:
 - straight-and-level flight
 - change of airspeed
 - constant airspeed climbs and descents
 - rate climbs and descents
 - timed turns to magnetic compass headings
 - Steep Turns
 - recovery from unusual flight attitudes
- Loss of gyro attitude and/or heading indicators
- Checking instruments and equipment post flight

Note: The patterns used in this Stage can be found in *Instrument Flying*, Chapter 9.

Completion Standards

Stage 1 is complete when the student achieves the objective of each lesson, and can list or describe the correct process or reference for accomplishing elements, exercises and activities. Student shall score at least 80% on the Stage 1 Exam, and all deficient areas shall be reconciled to 100%.

Stage 1 / **Module 1**

Minimum 141 Requirements: Dual, Instrument
1.5 hours flight
1.5 hours ground instruction



Ground Training

Objective:

For the student to have an understanding of the Instrument Rating course, and instrument scanning techniques.

Content:

- ___ Review of course and objectives
- ___ School requirements, procedures, regulations
- ___ Grading criteria, expectations of student
- ___ Review objective of Stage 1

Instrument scanning technique

- ___ Selective radial scan
- ___ Basic T-scan
- ___ Other scans

Completion Standards:

This lesson is complete when the student has successfully completed all review questions following the assigned reading.

Assignment:

Instrument Flying, Introduction and Chapters 1 and 2



This lesson may be completed using BATD Lesson 1. See Appendix 6.



Flight Training

Objective:

For the student to be introduced to the Instrument Rating course and become familiarized with the training airplane, instrument preflight, and straight-and-level instrument flight.

Content:

- ___ Discussion of flight training process
- ___ Introduction to the training airplane
- ___ Instrument preflight inspection and aircraft documents
- ___ Use of checklists
- ___ Normal takeoff
- ___ Instrument scan
- ___ Straight-and-level flight
- ___ Pattern A (see Chapter 9, *Instrument Flying*)
- ___ Pattern B (see Chapter 9, *Instrument Flying*)
- ___ Pattern C (see Chapter 9, *Instrument Flying*)
- ___ Radar vectors, VOR approach (demonstrated)
- ___ Postflight

Completion Standards:

This lesson is complete when the student can conduct an efficient instrument preflight and scan, and can maintain altitude within 200 feet, airspeed within 20 knots, and heading within 20 degrees, while performing the maneuvers listed in the content of this module.

Recommended Reading:

Instrument Flying

Stage 1 / **Module 1**

Date of Completion: _____

Signature: _____

Time Flown: _____

Aircraft _____ **BATD** _____ **Other** _____

Stage 1 / Module 2

Minimum 141 Requirements: Dual, Instrument
1.0 hours flight
1.0 hours ground instruction



Ground Training

Objective:

For the student to gain an understanding of the aircraft instruments used in instrument flight, and the concept of flying straight-and-level under instrument conditions.

Content:

Instruments

- ___ Attitude indicator
- ___ Power indicators
- ___ Airspeed indicator
- ___ Heading indicator
- ___ Altimeter
- ___ Vertical speed indicator
- ___ Turn coordinator and turn indicator
- ___ Magnetic compass
- ___ Clock
- ___ Pitot-static system
- ___ Gyroscopes
- ___ Preflight checks of flight instruments
- ___ PFD (if training aircraft warrants)

Straight-and-level flight

- ___ Control instruments
- ___ Performance instruments
- ___ 3 fundamentals of instrument flying
- ___ Trimming
- ___ Cruise speeds vs. pitch attitudes
- ___ Maintaining heading
- ___ Maintaining altitude
- ___ Recovering from slightly unusual attitudes
- ___ Coping with a faulty attitude indicator
- ___ Power vs. speed
- ___ Changing configuration

Completion Standards:

This lesson is complete when the student has successfully completed all review questions following the assigned reading.

Assignment:

Instrument Flying, Chapters 3 and 4



Flight Training

Objective:

For the student to become acquainted with the aircraft systems related to IFR operations, the instrument cockpit check, and to become proficient in flight by reference to instruments while maintaining changes of airspeed, and constant airspeed climbs and descents.

Content:

- ___ Discussion of aircraft systems related to IFR operations
- ___ Instrument cockpit check and preflight
- ___ Normal takeoff
- ___ Instrument scan
- ___ Straight-and-level flight
- ___ Standard rate turns
- ___ Demonstrate effects of change of airspeed
- ___ Constant airspeed climbs and descents
- ___ Pattern D (see Chapter 9, *Instrument Flying*)
- ___ Pattern E (see Chapter 9, *Instrument Flying*)
- ___ Pattern F (see Chapter 9, *Instrument Flying*)
- ___ Radar vectors, ILS approach (demonstrated)
- ___ Postflight

Completion Standards:

This module is complete when the student can effectively control the airplane within 200 feet, 20 degrees, and 20 knots, and perform standard rate turns, while performing the maneuvers listed in the content of this module.

Recommended Reading:

Instrument Flying



This lesson may be completed using BATD Lesson 2. See Appendix 6.

Stage 1 / **Module 2**

Date of Completion: _____

Signature: _____

Time Flown: _____

Aircraft _____ **BATD** _____ **Other** _____

Stage 1 / Module 3

Minimum 141 Requirements: Dual, Instrument
1.0 hours flight
1.0 hours ground instruction



Ground Training

Objective:

For the student to gain an understanding of the straight climb and descent, and turning during instrument flight.

Content:

The straight climb

- ___ Climbing at different airspeeds
- ___ Variations on entering the climb
- ___ Climbing at a particular rate
- ___ Climbing into clouds after takeoff

The straight descent

- ___ Climbing away from a descent
- ___ Descending at a particular rate
- ___ The precision approach

Turning

- ___ Bank angle and rate of turn
- ___ Roll-in and roll-out rate
- ___ The medium level turn
- ___ Instrument turns to a specific heading
- ___ Climbing turns
- ___ Descending turns
- ___ Steep Turns
- ___ Steep level turn
- ___ Steep descending turn

Completion Standards:

This lesson is complete when the student has successfully completed all review questions following the assigned reading.

Assignment:

Instrument Flying, Chapters 5 and 6



This lesson may be completed using BATD Lesson 3.
See Appendix 6.



Flight Training

Objective:

For the student to become proficient in performing Steep Turns and Slow Flight solely by reference to instruments, and understand the process of checking the instrument and equipment postflight.

Content:

- ___ Preflight inspection
- ___ Normal takeoff
- ___ Standard rate turns
- ___ Slow Flight
- ___ Steep Turns
- ___ Pattern I (see Chapter 9, *Instrument Flying*)
- ___ Pattern E (see Chapter 9, *Instrument Flying*)
- ___ Radar vectors, NDB or GPS approach (demonstrated)
- ___ Postflight, checking instruments and equipment

Completion Standards:

This module is complete when the student can perform Steep Turns, Slow Flight solely by reference to instruments, and postflight procedures, and can maintain flight within 150 feet, 15 degrees, 15 knots, and 5 degrees of bank angle, while performing the maneuvers listed in the content of this module.

Recommended Reading:

Instrument Flying

Stage 1 / **Module 3**

Date of Completion: _____

Signature: _____

Time Flown: _____

Aircraft _____ **BATD** _____ **Other** _____

Stage 1 / Module 4

Minimum 141 Requirements: Dual, Instrument
1.0 hours flight
1.0 hours ground instruction



Ground Training

Objective:

For the student to have an understanding of recognizing and recovering from unusual attitudes.

Content:

Unusual attitudes

- ___ Recognizing an unusual attitude
- ___ Nose-low attitudes with increasing airspeed
- ___ Nose-high attitude with decreasing airspeed
- ___ Nose-high and approaching the stall

Completion Standards:

This lesson is complete when the student has successfully completed all review questions following the assigned reading.

Assignment:

Instrument Flying, Chapter 7



This lesson may be completed using BATD Lesson 4.
See Appendix 6.



Flight Training

Objective:

For the student to become proficient at performing timed turns to magnetic compass headings, and constant rate climbs and descents, flying solely by reference to instruments.

Content:

- ___ Preflight
- ___ Soft-field takeoff
- ___ Standard rate turns
- ___ Steep Turns
- ___ Slow Flight
- ___ Power on/off Stalls
- ___ Timed turns to magnetic compass headings
- ___ Pattern G (see Chapter 9, *Instrument Flying*)
- ___ Pattern H (see Chapter 9, *Instrument Flying*)
- ___ Systems and equipment malfunctions
- ___ ASR approach (with tower or the instructor)
- ___ Postflight procedures

Completion Standards:

This module is complete when the student can maintain flight within 150 feet, 15 degrees, and 15 knots, while performing the maneuvers listed in the content of this module.

Recommended Reading:

Instrument Flying



This lesson may be completed using BATD Lesson 5.
See Appendix 6.

Stage 1 / **Module 4**

Date of Completion: _____

Signature: _____

Time Flown: _____

Aircraft _____ **BATD** _____ **Other** _____

Stage 1 / Module 5 and Stage Check



Ground Training

Objective:

For the student to gain an understanding of normal instrument flight on a partial panel and the maneuvers used in instrument flight training.

Content:

Normal instrument flight on a partial panel

- ___ Interpreting pitch attitude on a partial panel
- ___ Interpreting bank attitude on a partial panel
- ___ Straight flight on a partial panel
 - ___ straight-and-level flight on a partial panel
 - ___ climbing on a partial panel
 - ___ descending on a partial panel
- ___ Turning on a partial panel
- ___ Recovery from unusual attitudes on a partial panel

Training maneuvers

- ___ Seven-Ts
- ___ Performance sheets
- ___ Warm-ups
- ___ Maneuvers (A-K)

Completion Standards:

This lesson is complete when the student has successfully completed all review questions following the assigned reading. Stage 1 Exam must be passed with a minimum score of 80% and reconciled to 100%.

Assignment:

Instrument Flying, Chapters 8 and 9
Stage 1 Exam



This lesson may be completed using BATD Lesson 6.
See Appendix 6.

Minimum 141 Requirements: Dual, Instrument
1.5 hours flight
Stage check
1.5 hours ground instruction
Stage exam



Flight Training

Objective:

For the student to become proficient in recovery from unusual flight attitudes, and partial panel flight. For the Stage Check, student should demonstrate skill in the following areas according to the completion standards.

Content:

- ___ Preflight inspection
- ___ Aircraft systems related to IFR operations
- ___ Instrument cockpit check
- ___ Short-field takeoff
- ___ Straight-and-level flight
- ___ Change of airspeed
- ___ Constant airspeed climb and descents
- ___ Rate climbs and descents
- ___ Standard rate turns
- ___ Steep Turns
- ___ Slow Flight
- ___ Power on/off Stalls
- ___ Timed turns to headings
- ___ Recovery from unusual flight attitudes
- ___ Partial panel practice using patterns B and G
- ___ Pattern J (see Chapter 9, *Instrument Flying*)
- ___ Pattern H (see Chapter 9, *Instrument Flying*)
- ___ Radar vector approach (VOR, ILS, NDB, or GPS), instructor assisted
- ___ Checking instruments and equipment postflight

Completion Standards:

This module is complete when the student can recover from unusual flight attitudes, and fly partial panel. Student should maintain flight within 150 feet, 15 degrees, 15 knots, and 5 degrees of bank angle, while performing the maneuvers listed in the content of this module.

Recommended Reading:

Instrument Rating Test Prep, Chapters 3 and 4
Instrument Flying

Stage 1 / **Module 5**

Date of Completion: _____

Signature: _____

Time Flown: _____

Stage Exam Score: _____

Stage Check Successful: _____

Aircraft _____ **BATD** _____ **Other** _____

Optional **Stage 1 Review**



Flight Training

Objective:

For the student to review all Stage 1 tasks and meet all objectives.

Content:

- ___ Preflight inspection
- ___ Aircraft systems related to IFR operations
- ___ Instrument cockpit check
- ___ Short-field takeoff
- ___ Straight-and-level flight
- ___ Change of airspeed
- ___ Constant airspeed climbs and descents
- ___ Rate climbs and descents
- ___ Standard rate turns
- ___ Steep Turns
- ___ Slow Flight
- ___ Power on/off Stalls
- ___ Timed turns to headings
- ___ Recovery from unusual flight attitudes
- ___ Partial panel practice using patterns B and G
- ___ Pattern J (see Chapter 9, *Instrument Flying*)
- ___ Pattern H (see Chapter 9, *Instrument Flying*)
- ___ Radar vector approach (VOR, ILS, NDB, or GPS), instructor assisted
- ___ Checking instruments and equipment postflight

Completion Standards:

This module is complete when the student can recover from unusual flight attitudes, and fly partial panel. Student should maintain flight within 150 feet, 15 degrees, 15 knots, and 5 degrees of bank angle, while performing the maneuvers listed in the content of this module.

Recommended Reading:

Instrument Flying

Optional **Stage 1 Review**

Date of Completion: _____

Signature: _____

Time Flown: _____

Aircraft _____ **BATD** _____ **Other** _____

Stage 2

Navigation

Objective

The objective of Stage 2 is for the student to become proficient in and have an understanding of the following:



Ground Training

- Radio navigation aids
- Radar
- DME
- The NDB and ADF
- The Relative Bearing Indicator (RBI)
- The Radio Magnetic Indicator (RMI) and rotatable-card ADF
- The VOR
- The Instrument Landing System (ILS)
- RNAV using Pseudo-VORTACs or GPS



Flight Training

- ATC Clearances
- VOR navigation
- NDB navigation
- GPS navigation
- Intercepting and tracking VOR/VORTAC radials and DME arcs
- Intercepting and tracking NDB bearings
- Low Altitude Enroute chart use
- Airway use

Completion Standards

Stage 2 is complete when the student achieves the objective of each lesson and can list or describe the correct process or reference for accomplishing elements, exercises, and activities. Student shall score at least 80% on the Stage 2 Exam, and all deficient areas shall be reconciled to 100%.

Stage 2 / Module 1

Minimum 141 Requirements: Dual, Instrument
1.5 hours flight
1.5 hours ground instruction



Ground Training

Objective:

For the student to be introduced to radio navigation aids and gain an understanding of radar.

Content:

___ Review objective of Stage 2

Introduction to radio navigation aids

Radar

___ Radar vectoring

___ Radar approaches

___ Surveillance approaches

___ PAR approaches

___ No-gyro approaches

___ Using the transponder

___ How radar works

Completion Standards:

This lesson is complete when the student has successfully completed all review questions following the assigned reading.

Assignment:

Instrument Flying, Chapter 10



Flight Training

Objective:

For the student to become oriented with VOR homing and tracking procedures and to become proficient in ATC clearances.

Content:

___ Preflight inspection

___ Air Traffic Control clearances

___ VOR, VOT accuracy checks

___ TO-FROM and CDI orientation/use

___ Homing a VOR radial

___ Tracking a VOR radial

___ Effects of wind on VOR use

___ Tracking outbound/reverse sensing

___ Determining station passage

___ ASR approach, full panel (instructor assisted)

___ Postflight procedures

Completion Standards:

This module is complete when the student can communicate effectively with ATC, home and track using VOR radials, perform VOR accuracy checks, and orient himself/herself using a VOR. Flight should be maintained within 150 feet altitude, 15 knots airspeed, and 15 degrees heading, while performing the maneuvers listed in the content of this module.

Recommended Reading:

Instrument Flying

Stage 2 / **Module 1**

Date of Completion: _____

Signature: _____

Time Flown: _____

Aircraft _____ **BATD** _____ **Other** _____

Stage 2 / Module 2

Minimum 141 Requirements: Dual, Instrument
1.0 hours flight
1.0 hours ground instruction



Ground Training

Objective:

For the student to gain an operational understanding of DME and the VOR.

Content:

DME

- ___ DME measures slant distance
- ___ DME uses the principle of secondary radar
- ___ DME frequencies
- ___ VOR/DME pairing
- ___ ILS/DME pairing
- ___ DME arcs

VOR

- ___ VOR radial
- ___ How the VOR works
- ___ The range of a VOR
- ___ VORs on aeronautical charts
- ___ VOR/DME, TACAN, VORTAC
- ___ VOR cockpit instrument
- ___ TO or FROM
- ___ Preparing the OBI for use
- ___ Orientation using the VOR
- ___ Tracking using the VOR
- ___ Intercepting a course using the VOR
- ___ Other presentations of the VOR
- ___ The VOR instrument approach

Completion Standards:

This lesson is complete when the student has successfully completed all review questions following the assigned reading.

Assignment:

Instrument Flying, Chapters 12 and 14



This lesson may be completed using BATD Lesson 7.
See Appendix 6.



Flight Training

Objective:

For the student to become proficient at VOR navigation and intercepting and tracking VOR/VORTAC radials and DME arcs.

Content:

- ___ Preflight
- ___ ATC clearances
- ___ VOR/VOT accuracy checks
- ___ VOR navigation techniques
- ___ Homing a VOR radial
- ___ Intercepting and tracking VOR/VORTAC radials
- ___ DME arcs
- ___ VOR full approach (instructor assisted)
- ___ Postflight procedures

Completion Standards:

This module is complete when the student can navigate using VORs, and can intercept and track VOR/VORTAC radials and DME arcs. Flight should be maintained within 150 feet altitude, 15 knots airspeed, and 15 degrees heading, while performing the maneuvers listed in the content of this module.

Recommended Reading:

Instrument Flying



This lesson may be completed using BATD Lesson 8.
See Appendix 6.

Stage 2 / **Module 2**

Date of Completion: _____

Signature: _____

Time Flown: _____

Aircraft _____ **BATD** _____ **Other** _____

Stage 2 / Module 3

Minimum 141 Requirements: Dual, Instrument
1.0 hours flight
1.0 hours ground instruction



Ground Training

Objective:

For the student to gain an operational understanding of the NDB and ADF, the relative bearing indicator (RBI), the radio magnetic indicator (RMI), and the rotatable-card ADF.

Content:

The NDB and the ADF

- ___ The Automatic Direction Finder
- ___ The ADF Cockpit Display

The Relative Bearing Indicator (RBI)

- ___ Operational use of the RBI
- ___ Tracking
- ___ The NDB approach

The Radio Magnetic Indicator (RMI) and Rotatable-card ADF

- ___ Orientation using the RMI
- ___ The initial interception of course
- ___ Maintaining course

Completion Standards:

This lesson is complete when the student has successfully completed all review questions following the assigned reading.

Assignment:

Instrument Flying, Chapter 11



This lesson may be completed using BATD Lesson 9.
See Appendix 6.



Flight Training

Objective:

For the student to become proficient with NDB navigation and intercepting and tracking NDB bearings.

Content:

- ___ Preflight
- ___ ATC clearances
- ___ ADF orientation
- ___ NDB navigation
- ___ Homing with an NDB
- ___ Tracking with an NDB
- ___ Intercepting NDB bearings
- ___ NDB full approach (instructor assisted)
- ___ Postflight procedures

Completion Standards:

This module is complete when the student can navigate using the NDB, and intercept and track NDB bearings. Flight should be maintained within 150 feet altitude, 15 knots airspeed, and 15 degrees heading, while performing the maneuvers listed in the content of this module.

Recommended Reading:

Instrument Flying



This lesson may be completed using BATD Lesson 10.
See Appendix 6.

Stage 2 / **Module 3**

Date of Completion: _____

Signature: _____

Time Flown: _____

Aircraft _____ **BATD** _____ **Other** _____

Stage 2 / Module 4

Minimum 141 Requirements: Dual, Instrument
1.0 hours flight
1.0 hours ground instruction



Ground Training

Objective:

For the student to gain an operational understanding of the Instrument Landing System (ILS).

Content:

Instrument Landing System (ILS)

- ___ The Localizer
 - ___ flying the Localizer
 - ___ flying the Localizer with an HSI
- ___ The Glideslope
 - ___ flying the glideslope
- ___ Marker Beacons
 - ___ other means of checking glideslope
- ___ Approach lights and other lights
 - ___ approach light systems (ALS)
 - ___ visual approach slope indicator (VASI)
 - ___ runway lighting
 - ___ taxiway lights
 - ___ control of lighting systems
- ___ Precision instrument runway markings
- ___ Inoperative ILS components
- ___ Flying a typical ILS
- ___ International terminology
- ___ Simultaneous approaches
- ___ The sidestep maneuver
- ___ The localizer-type directional aid (LDA)
- ___ The simplified directional facility (SDF)
- ___ Windshear on the approach
 - ___ windshear terminology
 - ___ windshear effects on an aircraft's flightpath
 - ___ the causes of windshear

Completion Standards:

This lesson is complete when the student has successfully completed all review questions following the assigned reading.

Assignment:

Instrument Flying, Chapter 13



This lesson may be completed using BATD Lesson 11. See Appendix 6.



Flight Training

Objective:

For the student to be introduced to Low Altitude Enroute chart use and to become proficient with Time to Station problems, VOR navigation, DME arcs, NDB navigation, GPS navigation, and intercepting NDB bearings and VOR radials.

Content:

- ___ Preflight
- ___ ATC clearances
- ___ Low Altitude Enroute chart orientation and use
- ___ DME arcs
- ___ VOR navigation
- ___ NDB navigation
- ___ GPS navigation
- ___ Intercepting and tracking VOR radials
- ___ Intercepting and tracking NDB bearings
- ___ NDB time to station problems
- ___ VOR time to station problems
- ___ ILS full approach (instructor assisted)
- ___ Postflight procedures

Completion Standards:

This module is complete when the student can understand and apply the techniques used in DME arcs, VOR navigation, NDB navigation, and low altitude enroute chart use, and accurately perform VOR and NDB Time to Station problems. Flight should be maintained within 150 feet altitude, 15 knots airspeed, and 15 degrees heading, while performing the maneuvers listed in the content of this module.

Recommended Reading:

Instrument Flying

Stage 2 / **Module 4**

Date of Completion: _____

Signature: _____

Time Flown: _____

Aircraft _____ **BATD** _____ **Other** _____

Stage 2 / Module 5 and Stage Check



Ground Training

Objective:

For the student to gain an operational understanding of RNAV.

Content:

RNAV

- ___ Pseudo-VORTACs
- ___ DPs and approaches
- ___ GPS

Completion Standards:

This lesson is complete when the student has successfully completed all review questions following the assigned reading. Stage 2 Exam must be passed with a minimum score of 80% and reconciled to 100%.

Assignment:

Instrument Flying, Chapter 15
Stage 2 Exam

Minimum 141 Requirements: Dual, Instrument
1.5 hours flight
Stage check
1.5 hours ground instruction
Stage exam



Flight Training

Objective:

For the student to review how to home, track, and intercept VOR and NDB radials/bearings, navigate using VORs, NDBs, or GPS, comply with ATC clearances, correctly use a Low Altitude Enroute chart, and be introduced to airway use. For the Stage Check, student should demonstrate skill in the following areas according to the completion standards.

Content:

- ___ Preflight
- ___ ATC clearances
- ___ VOR/VOT accuracy check
- ___ VOR navigation
- ___ NDB navigation
- ___ Intercepting and tracking VOR radials
- ___ Intercepting and tracking NDB bearings
- ___ Low Altitude Enroute chart use and orientation
- ___ Airway orientation with instruments and charts
- ___ Standard rate turns
- ___ Steep Turns
- ___ Slow Flight
- ___ Power on/off Stalls
- ___ Timed turns to headings
- ___ Recovery from unusual flight attitudes
- ___ Partial panel practice using patterns B and G
- ___ Full approach (VOR, NDB, GPS, or ILS), instructor assisted
- ___ Postflight procedures

Completion Standards:

This lesson is complete when the student can perform all maneuvers listed in the content of this module, while maintaining VOR and NDB navigation within 2 dots or 5 degrees of course, and altitude within 100 feet, heading within 10 degrees, and airspeed within 10 knots.

Recommended Reading:

Instrument Flying
Instrument Rating Test Prep, Chapter 8

Stage 2 / **Module 5**

Date of Completion: _____

Signature: _____

Time Flown: _____

Stage Exam Score: _____

Stage Check Successful: _____

Aircraft _____ **BATD** _____ **Other** _____

Optional **Stage 2 Review**



Flight Training

Objective:

For the student to review all Stage 2 tasks and meet all objectives.

Content:

- ___ Preflight
- ___ ATC clearances
- ___ VOR/VOT accuracy check
- ___ VOR navigation
- ___ NDB navigation
- ___ GPS navigation
- ___ Intercepting and tracking VOR radials
- ___ Intercepting and tracking NDB bearings
- ___ Low Altitude Enroute chart use and orientation
- ___ Airway orientation with instruments and charts
- ___ Standard rate turns
- ___ Steep Turns
- ___ Slow Flight
- ___ Power on/off Stalls
- ___ Timed turns to headings
- ___ Recovery from unusual flight attitudes
- ___ Partial panel practice using patterns B and G
- ___ Full approach (VOR, NDB, GPS, or ILS), instructor assisted
- ___ Postflight procedures

Completion Standards:

This lesson is complete when the student can perform all maneuvers listed in the content of this module, while maintaining VOR and NDB navigation within 2 dots or 5 degrees of course, and altitude within 100 feet, heading within 10 degrees, and airspeed within 10 knots.

Recommended Reading:

Instrument Flying

Optional **Stage 2 Review**

Date of Completion: _____

Signature: _____

Time Flown: _____

Aircraft _____ **BATD** _____ **Other** _____

Stage 3

Holding Procedures

Objective

The objective of Stage 3 is for the student to become proficient in and have an understanding of the following:



Ground Training

- Holding patterns
- Procedure turns
- DME arcs
- Regulations pertaining to the instrument pilot
- Preparation for instrument flight
- Icing
- Visibility



Flight Training

- Holding procedures:
 - entries to holds
 - holding at VORs
 - holding at NDBs
 - holding at intersections
 - partial panel holds
 - holding speeds
- Compliance with departure, en route, and arrival procedures and clearances
- Filing an IFR flight plan

Completion Standards

Stage 3 is complete when the student achieves the objective of each lesson, and can list or describe the correct process or reference for accomplishing elements, exercises and activities. Student shall score at least 80% on the Stage 3 Exam, and all deficient areas shall be reconciled to 100%.

Stage 3 / Module 1

Minimum 141 Requirements: Dual, Instrument
1.5 hours flight
1.5 hours ground instruction



Ground Training

Objective:

For the student to gain an understanding of holding patterns, procedure turns, and DME arcs.

Content:

___ Review objective of Stage 3

Holding patterns

___ Tracking

___ Corrections for wind

___ Entering a holding pattern

___ Holding speeds

Procedure turns

___ The 45°/180° procedure turn

___ The 80°/260° procedure turn

___ The base turn, or teardrop turn

___ Positioning in a racetrack pattern

DME Arcs

Completion Standards:

This lesson is complete when the student has successfully completed all review questions following the assigned reading.

Assignment:

Instrument Flying, Chapter 28



This lesson may be completed using BATD Lesson 12.
See Appendix 6.



Flight Training

Objective:

For the student to be introduced to entries to holds and holding at VORs.

Content:

___ Instrument preflight

___ Holding instruction

___ Perform three holds at a VOR

___ Direct entry, standard turns

___ Parallel entry, nonstandard turns

___ Teardrop entry, standard turns

___ VOR approach, radar vectors (instructor assisted)

___ Postflight procedures

Completion Standards:

This module is complete when the student has an understanding of entries to holds, and can perform a hold using a VOR. Student should maintain altitude within 150 feet, airspeed within 15 knots, and heading within 15 degrees, while performing the maneuvers listed in the content of this module.

Recommended Reading:

Instrument Flying



This lesson may be completed using BATD Lesson 13.
See Appendix 6.

Stage 3 / **Module 1**

Date of Completion: _____

Signature: _____

Time Flown: _____

Aircraft _____ **BATD** _____ **Other** _____

Stage 3 / Module 2

Minimum 141 Requirements: Dual, Instrument
1.0 hours flight
1.0 hours ground instruction



Ground Training

Objective:

For the student to understand the federal aviation regulations which pertain to the instrument pilot.

Content:

Regulations pertaining to the instrument pilot

- ___ Federal Aviation Regulations
- ___ Responsibility and authority of the PIC
- ___ What is IFR?
- ___ Am I qualified to fly IFR today?
- ___ Is the airplane suitable for IFR?
- ___ IFR operations

Completion Standards:

This lesson is complete when the student has successfully completed all review questions following the assigned reading.

Assignment:

Instrument Flying, Chapter 24



Flight Training

Objective:

For the student to become proficient at holding entry procedures, performing standard and nonstandard holding patterns, complying with departure, en route, and arrival procedures and clearances, and filing an IFR flight plan.

Content:

- ___ Instrument preflight
- ___ Departure procedures
- ___ File an IFR flight plan
- ___ Comply with departure, en route, and arrival procedures and clearances
- ___ Perform 3 VOR holds, using direct, parallel, and teardrop entries
- ___ Demonstrate both standard and nonstandard holding patterns
- ___ Perform 1 VOR hold, using partial panel
- ___ ILS approach, radar vectors (instructor assisted)
- ___ Postflight procedures

Completion Standards:

This module is complete when the student can accurately hold at a VOR using the proper entry procedure and timing techniques, maintaining orientation to whereabouts at all times. Student must maintain altitude within 150 feet, airspeed within 15 knots, and heading within 15 degrees, while performing the maneuvers listed in the content of this module.

Recommended Reading:

Instrument Flying

Stage 3 / **Module 2**

Date of Completion: _____

Signature: _____

Time Flown: _____

Aircraft _____ **BATD** _____ **Other** _____

Stage 3 / Module 3

Minimum 141 Requirements: Dual, Instrument
1.0 hours flight
1.0 hours ground instruction



Ground Training

Objective:

For the student to understand the preparation necessary for an instrument flight.

Content:

Preparation for flight

- ___ Preflight considerations for an IFR flight
- ___ En Route charts
 - ___ airports
 - ___ navigation aids
 - ___ routes
 - ___ airspace
 - ___ communications
- ___ Flight planning
 - ___ the flight plan

Completion Standards:

This lesson is complete when the student has successfully completed all review questions following the assigned reading.

Assignment:

Instrument Flying, Chapter 25



Flight Training

Objective:

For the student to become proficient in performing holds at an NDB.

Content:

- ___ Instrument preflight
- ___ Departure procedures
- ___ File an IFR flight plan
- ___ Perform NDB hold, standard and nonstandard turns
- ___ Perform NDB hold, partial panel
- ___ Review VOR holding procedures
- ___ NDB or GPS full approach (instructor assisted)
- ___ Postflight procedures

Completion Standards:

This module is complete when the student can perform holds at an NDB using the correct entry and timing procedures, maintaining orientation to whereabouts at all times. Student must maintain altitude within 150 feet, airspeed within 15 knots, and heading within 15 degrees, while performing the maneuvers listed in the content of this module.

Recommended Reading:

Instrument Flying



This lesson may be completed using BATD Lesson 14.
See Appendix 6.

Stage 3 / **Module 3**

Date of Completion: _____

Signature: _____

Time Flown: _____

Aircraft _____ **BATD** _____ **Other** _____

Stage 3 / Module 4

Minimum 141 Requirements: Dual, Instrument
1.0 hours flight
1.0 hours ground instruction



Ground Training

Objective:

For the student to gain an understanding of IFR meteorology, specifically icing.

Content:

Icing

- ___ Structural Icing
 - ___ clear ice
 - ___ rime ice
 - ___ mixed (or cloudy) ice
 - ___ frost
 - ___ structural icing and cloud type
- ___ Induction Icing
 - ___ carburetor icing
 - ___ engine intake icing
- ___ Some hints to the pilot flying in icing conditions

Completion Standards:

This lesson is complete when the student has successfully completed all review questions following the assigned reading.

Assignment:

Instrument Flying, Chapter 20



Flight Training

Objective:

For the student to perform partial panel and intersection holds.

Content:

- ___ Instrument preflight
- ___ File an IFR flight plan
- ___ VOR hold, partial panel
- ___ Intersection hold, partial panel
- ___ NDB hold, partial panel
- ___ VOR full approach (instructor assisted)
- ___ Postflight procedures

Note: Students should practice a different entry technique with each hold.

Completion Standards:

This module is complete when the student can perform VOR, Intersection, and NDB holds using a partial panel, maintaining orientation to whereabouts at all times. Student must maintain altitude within 150 feet, airspeed within 15 knots, and heading within 15 degrees, while performing the maneuvers listed in the content of this module.

Recommended Reading:

Instrument Flying

Stage 3 / **Module 4**

Date of Completion: _____

Signature: _____

Time Flown: _____

Aircraft _____ **BATD** _____ **Other** _____

Stage 3 / Module 5 and Stage Check



Ground Training

Objective:

For the student to gain an understanding of IFR meteorology, specifically visibility.

Content:

Visibility

- ___ Inversions and reduced visibility
- ___ Condensation
- ___ Fog
 - ___ radiation fog
 - ___ advection fog
 - ___ upslope fog
 - ___ frontal fog
 - ___ steam fog

Completion Standards:

This lesson is complete when the student has successfully completed all review questions following the assigned reading. Stage 3 Exam must be passed with a minimum score of 80% and reconciled to 100%.

Assignment:

Instrument Flying, Chapter 18
Stage 3 Exam

Minimum 141 Requirements: Dual, Instrument
1.5 hours flight
Stage check
1.5 hours ground instruction
Stage exam



Flight Training

Objective:

For the student to review VOR, Intersection, NDB—standard and nonstandard—holds, with both full and partial panel; and instrument flying maneuvers. For the Stage Check, student should demonstrate skill in the following areas according to the completion standards.

Content:

- ___ Instrument preflight
 - ___ File IFR flight plan
 - ___ Comply with departure, en route, and arrival procedures and clearances
 - ___ VOR hold
 - ___ Intersection hold
 - ___ NDB hold
 - ___ Slow Flight
 - ___ Steep Turns
 - ___ Power on/off Stalls
 - ___ ILS full approach (instructor assisted)
 - ___ Postflight procedures
- Note: Students should demonstrate holds using all entry procedures and full and partial panel proficiency.*

Completion Standards:

This module is complete when the student can perform VOR, Intersection, and NDB holds, demonstrating all entry procedures, standard and nonstandard patterns, and full and partial panel proficiency. Student must maintain altitude within 100 feet, airspeed within 10 knots, and heading within 10 degrees, while performing the maneuvers listed in the content of this module.

Recommended Reading:

Instrument Flying
Instrument Rating Test Prep, Chapter 5

Stage 3 / **Module 5**

Date of Completion: _____

Signature: _____

Time Flown: _____

Stage Exam Score: _____

Stage Check Successful: _____

Aircraft _____ **BATD** _____ **Other** _____

Optional **Stage 3 Review**



Lesson Time: Dual, Instrument
1.5 hours flight, or whatever is necessary to meet objective
1.5 hour ground instruction, or whatever is necessary to meet objective

Flight Training

Objective:

For the student to review all Stage 3 tasks and meet all objectives.

Content:

- ___ Instrument preflight
- ___ File IFR flight plan
- ___ Comply with departure, en route, and arrival procedures and clearances
- ___ VOR hold
- ___ Intersection hold
- ___ NDB hold
- ___ Slow Flight
- ___ Steep Turns
- ___ Power on/off Stalls
- ___ ILS full approach (instructor assisted)
- ___ Postflight procedures

Note: Students should demonstrate holds using all entry procedures and full and partial panel proficiency.

Completion Standards:

This module is complete when the student can perform VOR, Intersection, and NDB holds, demonstrating all entry procedures, standard and nonstandard patterns, and full and partial panel proficiency. Student must maintain altitude within 100 feet, airspeed within 10 knots, and heading within 10 degrees, while performing the maneuvers listed in the content of this module.

Recommended Reading:

Instrument Flying

Optional Stage 3 Review
Date of Completion: _____
Signature: _____
Time Flown: _____
Aircraft _____ BATD _____ Other _____

Stage 4

Instrument Approaches

Objective

The objective of Stage 4 is for the student to become proficient in and have an understanding of the following:



Ground Training

- Instrument approaches
- Instrument departures
- Visual maneuvering
- Clouds
- Thunderstorms
- High-level meteorology



Flight Training

- VOR/VORTAC instrument approach procedure
- NDB instrument approach procedure
- ILS instrument approach procedure
- GPS instrument approach procedure
- Missed approach procedures
- Circling approach procedures
- Landing from a straight-in or circling approach procedure
- Localizer instrument approach procedure
- Localizer back-course approach
- Instrument approaches from holds
- Partial panel approaches
- Loss of communications

Completion Standards

Stage 4 is complete when the student achieves the objective of each lesson, and can list or describe the correct process or reference for accomplishing elements, exercises and activities. Student shall score at least 80% on the Stage 4 Exam, and all deficient areas shall be reconciled to 100%.

Stage 4 / Module 1

Minimum 141 Requirements: Dual, Instrument
1.5 hours flight
1.5 hours ground instruction



Ground Training

Objective:

For the student to gain an operational understanding of arrivals, instrument approaches, and instrument approach charts.

Content:

___ Review objective of Stage 4

Arrivals

___ Standard Terminal Arrival Routes (STARs)

Vertical navigation

The instrument approach

___ The segments of an instrument approach

Instrument approach charts

___ The elements of an instrument approach chart

___ Identification of an instrument approach chart

___ Radio communications frequencies

___ Plan view of the instrument approach

___ Profile view

___ The minimum safe altitude circle (MSA)

___ Approach minimums

___ Timing to the missed approach point

___ Typical instrument approach charts

___ General comments on instrument approaches

___ Visual reference at the DH or MDA

___ Visual illusions on approach

Completion Standards:

This lesson is complete when the student has successfully completed all review questions following the assigned reading.

Assignment:

Instrument Flying, Chapter 29



Flight Training

Objective:

For the student to become proficient in performing VOR approaches—full, radar vectors, straight-in, circle-to-land—and missed approach techniques.

Content:

___ Instrument Preflight

___ File an IFR flight plan

___ Full VOR approach, followed by missed approach procedures

___ Radar vectors VOR approach, using straight-in minimums

___ Partial panel VOR radar vectors approach, using circle-to-land minimums

___ Postflight procedures

Completion Standards:

This module is complete when the student can perform VOR approaches (full, radar vectors, straight-in, and circle-to-land) within 100 feet of altitude, and 3 dots of the CDI needle. The student must comply with all ATC clearances and perform all procedures according to the approach plates.

Recommended Reading:

Instrument Flying



This lesson may be completed using BATD Lesson 15. See Appendix 6.

Stage 4 / **Module 1**

Date of Completion: _____

Signature: _____

Time Flown: _____

Aircraft _____ **BATD** _____ **Other** _____

Stage 4 / Module 2

Minimum 141 Requirements: Dual, Instrument
1.0 hours flight
1.0 hours ground instruction



Ground Training

Objective:

For the student to gain an operational understanding of the instrument departure.

Content:

Instrument departures

- ___ Weather at the departure airport
- ___ Takeoff minimums
- ___ Setting course
- ___ Departure Procedures (DPs)
- ___ ATC clearances

Completion Standards:

This lesson is complete when the student has successfully completed all review questions following the assigned reading.

Assignment:

Instrument Flying, Chapter 26



This lesson may be completed using BATD Lesson 16. See Appendix 6.



Flight Training

Objective:

For the student to become proficient in performing NDB and/or GPS approaches, demonstrating full, radar vectors, straight-in, circle-to-land, and missed approach techniques.

Note: Applicants will be required to demonstrate GPS approach proficiency if the aircraft includes a properly installed GPS.

Content:

- ___ Instrument preflight
- ___ File an IFR flight plan
- ___ NDB and/or GPS full approach, followed by missed approach
- ___ NDB and/or GPS radar vector approach, using straight-in minimums
- ___ NDB and/or GPS partial panel, radar vector approach, using circle-to-land minimums
- ___ Postflight procedures

Completion Standards:

This module is complete when the student can perform NDB full, radar vectors, missed, circle-to-land, and straight-in approaches while maintaining flight within 100 feet above minimum descent altitude, not descending lower until a decision to land has been made. The student must maintain the flight within $\pm 10^\circ$ of the runway at the missed approach point.

Recommended Reading:

Instrument Flying

Stage 4 / **Module 2**

Date of Completion: _____

Signature: _____

Time Flown: _____

Aircraft _____ **BATD** _____ **Other** _____

Stage 4 / Module 3

Minimum 141 Requirements: Dual, Instrument
1.0 hours flight
1.0 hours ground instruction



Ground Training

Objective:

For the student to gain an understanding of visual maneuvering, including circling to land, contact approaches, visual approaches, visual illusions, wake turbulence on approach, and hydroplaning.

Content:

Visual maneuvering

- Circling to land
 - the visual circling maneuver
 - the visual maneuvering (circling) area
 - sectorized visual maneuvering (circling) areas
 - the missed approach procedure when circling
 - approaches with circling minimums only
 - airports without a published IAP
- Contact approach
- Visual approach
- Visual illusions
- Wake turbulence on approach
- Hydroplaning

Completion Standards:

This lesson is complete when the student has successfully completed all review questions following the assigned reading.

Assignment:

Instrument Flying, Chapter 30



Flight Training

Objective:

For the student to become proficient in performing ILS and Localizer approaches, including missed approach, full and radar vector techniques.

Content:

- Instrument preflight
- Discuss initiating the missed approach before reaching the missed approach point
- File an IFR flight plan
- ILS full approach, followed by missed approach
- ILS radar vector approach, using straight-in minimums
- Localizer radar vector approach, using circle-to-land minimums
- Localizer back course full approach, using straight-in minimums
- Postflight procedures

Completion Standards:

This module is complete when the student can perform ILS full and radar vector approaches, and Localizer approaches without descending below the minimum altitudes, and while maintaining airspeed within 10 knots of approach speed, and arriving at the MDA prior to the MAP and performing a prompt missed approach at the accurate time. ILS approach must maintain glideslope within less than full needle deflection.

Recommended Reading:

Instrument Flying



This lesson may be completed using BATD Lesson 17.
See Appendix 6.

Stage 4 / **Module 3**

Date of Completion: _____

Signature: _____

Time Flown: _____

Aircraft _____ **BATD** _____ **Other** _____

Stage 4 / Module 4

Minimum 141 Requirements: Dual, Instrument
1.5 hours flight
1.0 hours ground instruction



Ground Training

Objective:

For the student to gain an understanding of IFR meteorology, specifically clouds and thunderstorms.

Content:

Clouds

- ___ The naming of clouds
- ___ Moisture in the atmosphere
- ___ The formation of clouds
- ___ Precipitation from clouds
- ___ Lifted index

Thunderstorms

- ___ The life cycle of a thunderstorm
- ___ Downbursts and microbursts
- ___ Tornadoes and water spouts
- ___ Thunderstorms are hazardous to aviation
- ___ Weather radar
- ___ Stormscopes

Completion Standards:

This lesson is complete when the student has successfully completed all review questions following the assigned reading.

Assignment:

Instrument Flying, Chapters 19 and 21



Flight Training

Objective:

For the student to demonstrate a proficient VOR hold and approach, NDB hold and approach, and ILS approach. Student will gain an understanding of IFR lost communication procedures.

Content:

- ___ Instrument preflight
- ___ File an IFR flight plan
- ___ VOR hold
- ___ VOR approach
- ___ NDB hold
- ___ NDB approach
- ___ GPS approach (if aircraft properly equipped)
- ___ ILS approach
- ___ IFR lost communication procedures
- ___ Postflight procedures

Instructor should request holding entries and full/radar vectors based on areas the student is least proficient.

Completion Standards:

This module is complete when the student can perform the flight with little assistance from the instructor, and maintain flight within 10 knots airspeed, 100 feet altitude, without descending below any minimum altitudes. Student will demonstrate IFR lost communication procedures.

Recommended Reading:

Instrument Flying

Stage 4 / **Module 4**

Date of Completion: _____

Signature: _____

Time Flown: _____

Aircraft _____ **BATD** _____ **Other** _____

Stage 4 / Module 5 and Stage Check



Ground Training

Objective:

For the student to gain an understanding of IFR meteorology, specifically high-level meteorology.

Content:

High-level meteorology

___ Jet streams

___ Clouds at high levels

Completion Standards:

This lesson is complete when the student has successfully completed all review questions following the assigned reading. Stage 4 Exam must be passed with a minimum score of 80% and reconciled to 100%.

Assignment:

Instrument Flying, Chapter 22

Minimum 141 Requirements: Dual, Instrument
1.5 hours flight
Stage check
1.5 hours ground instruction
Stage exam



Flight Training

Objective:

For the student to review VOR, NDB, ILS, and Localizer approaches, using missed, circling, straight-in, full/radar vectors, partial panel, and lost communication techniques. For the Stage Check, student should demonstrate skill in the following areas according to the completion standards.

Content:

___ Instrument preflight

___ File an IFR flight plan

___ VOR approach

___ NDB approach

___ GPS approach (if aircraft properly equipped)

___ ILS approach

___ Localizer approach

___ IFR lost communication procedures

___ Postflight procedures

Instructor should request missed, circling, straight-in, partial panel, and full/radar vectors based on areas the student is least proficient.

Completion Standards:

This module is complete when the student can conduct the flight using efficient cockpit management skills in instrument conditions, and demonstrate VOR, NDB, ILS, and Localizer approaches under the conditions stated by the instructor without busting the minimums set out by each approach. Flight must be maintained at altitude within 100 feet, heading within 10 degrees, and airspeed within 10 knots.

Recommended Reading:

Instrument Flying

Instrument Test Prep, Chapters 6 and 7

Stage 4 / **Module 5**

Date of Completion: _____

Signature: _____

Time Flown: _____

Stage Exam Score: _____

Stage Check Successful: _____

Aircraft _____ **BATD** _____ **Other** _____

Optional **Stage 4 Review**



Flight Training

Objective:

For the student to review all Stage 4 tasks and meet all objectives.

Content:

- ___ Instrument preflight
- ___ File an IFR flight plan
- ___ VOR approach
- ___ NDB approach
- ___ GPS approach (if aircraft properly equipped)
- ___ ILS approach
- ___ Localizer approach
- ___ IFR lost communication procedures
- ___ Postflight procedures

Instructor should request missed, circling, straight-in, partial panel, and full/radar vectors based on areas the student is least proficient.

Completion Standards:

This module is complete when the student can conduct the flight using efficient cockpit management skills in instrument conditions, and demonstrate VOR, NDB, ILS, and Localizer approaches under the conditions stated by the instructor without busting the minimums set out by each approach. Flight must be maintained at altitude within 100 feet, heading within 10 degrees, and airspeed within 10 knots.

Recommended Reading:

Instrument Flying

Optional **Stage 4 Review**

Date of Completion: _____

Signature: _____

Time Flown: _____

Aircraft _____ **BATD** _____ **Other** _____

Stage 5

En Route & Prep for Checkride

Objective

The objective of Stage 5 is for the student to become proficient in and have an understanding of the following:



Ground Training

- Enroute procedures
- Wind, air masses, and fronts
- Weather reports and forecasts
- Review Instrument Practical Test Standards
- Oral prep for the checkride
- Take and pass the FAA Knowledge Exam



Flight Training

- Enroute procedures
- Weather information
- Cross-country flight planning
- Instrument cross-country
- Emergency procedures
- Review of Instrument Practical Test Standards
- Sign-off for the Instrument Checkride

Completion Standards

Stage 5 is complete when the student achieves the objective of each lesson and can list or describe the correct process or reference for accomplishing elements, exercises, and activities. Student shall score at least 80% on the Stage 5 Exam, and all deficient areas shall be reconciled to 100%. Upon completion of this stage, student will take the Instrument Rating checkride.

Stage 5 / Module 1



Ground Training

Objective:

For the student to gain an understanding of enroute procedures on an IFR flight.

Content:

___ Review objective of Stage 5

En route

___ Radar service

___ Enroute clearances

___ Position reports

___ Additional compulsory radio reports

___ Flying the airways

___ High altitude flying and oxygen

___ VFR-on-top

___ DME failure

___ Enroute diversions

___ Minimum fuel

___ Canceling an IFR flight plan

Completion Standards:

This lesson is complete when the student has successfully completed all review questions following the assigned reading.

Assignment:

Instrument Flying, Chapter 27

Minimum 141 Requirements: Dual, Instrument
Cross-country
2.0 hours flight
1.5 hours ground instruction



Flight Training

Objective:

For the student to demonstrate proficiency in planning an IFR cross-country, enroute procedures, and performing a short round-robin that includes an ILS, NDB or GPS, and VOR approach.

Content:

___ Preflight

___ Plan IFR round-robin cross-country

___ Instrument preflight

___ Round-robin IFR cross-country flight

___ Simulated loss of communications

___ Simulated engine failure

___ Simulated instrument failure

___ Simulated radio failure

___ NDB or GPS approach

___ VOR approach

___ ILS approach

___ Postflight procedures

Note: One approach should be performed using a partial panel.

Completion Standards:

This module is complete when the student can accurately plan an IFR cross-country flight, demonstrate correct enroute procedures, and perform this flight, including an ILS, NDB, and VOR approach, while maintaining flight within ± 100 feet altitude, ± 10 degrees of heading, ± 10 knots airspeed, and approaches within specified minimums.

Recommended Reading:

Instrument Flying

Stage 5 / **Module 1**

Date of Completion: _____

Signature: _____

Time Flown: _____

Aircraft _____ **BATD** _____ **Other** _____

Stage 5 / Module 2



Ground Training

Objective:

For the student to gain an understanding of IFR meteorology, specifically wind, air masses, and fronts.

Content:

- ___ The nature of the atmosphere
- ___ The cause of weather

Winds

- ___ Windshear

Air masses and frontal weather

- ___ The warm front
- ___ The cold front
- ___ The occluded front

Depressions—areas of low pressure

- ___ Weather associated with a depression
- ___ Troughs of low pressure
- ___ The wave or frontal depression
- ___ The hurricane or tropical revolving storm

Anticyclones—areas of high pressure

- ___ Weather associated with a high
- ___ A ridge of high pressure
- ___ A col

Completion Standards:

This lesson is complete when the student has successfully completed all review questions following the assigned reading.

Assignment:

Instrument Flying, Chapter 17

Minimum 141 Requirements: Dual, Instrument
Cross-country
2.0 hours flight
1.0 hours ground instruction



Flight Training

Objective:

For the student to demonstrate proficiency in all IFR cross-country procedures while performing a short round robin, including holds, approaches, and partial panel work.

Content:

- ___ Plan IFR cross-country
- ___ Instrument preflight
- ___ Round-robin cross-country flight
- ___ Simulated loss of communications
- ___ Simulated engine failure
- ___ Simulated instrument failure
- ___ Simulated radio failure
- ___ VOR hold
- ___ NDB hold
- ___ VOR approach
- ___ NDB approach
- ___ GPS approach (if aircraft properly equipped)
- ___ ILS approach
- ___ Partial panel work
- ___ Postflight procedures

Completion Standards:

This module is complete when the student can perform IFR cross-country procedures using good cockpit management skills, can maintain flight within ± 100 feet, ± 10 knots, and ± 10 degrees, and can perform approaches within specified minimums.

Recommended Reading:

Instrument Flying

Stage 5 / Module 2
Date of Completion: _____
Signature: _____
Time Flown: _____
Aircraft _____ BATD _____ Other _____

Stage 5 / Module 3



Ground Training

Objective:

For the student to gain an understanding of IFR meteorology, specifically weather reports and forecasts.

Content:

Obtaining a weather briefing

Weather reports

- ___ Weather depiction charts
- ___ Surface analysis charts
- ___ Radar summary charts
- ___ METARs
- ___ Pilot weather reports (PIREPs)

Weather forecasts

- ___ Low-level significant weather prognostic charts
- ___ Area forecasts
- ___ Terminal forecasts (TAF)
- ___ The convective outlook (AC)
- ___ Winds and temperature aloft forecasts (FB)
- ___ Severe weather outlook charts (AC)
- ___ Constant pressure analysis charts
- ___ Tropopause data charts
- ___ Other weather information
- ___ Staying informed in the air

Completion Standards:

This lesson is complete when the student has successfully completed all review questions following the assigned reading.

Assignment:

Instrument Flying, Chapter 23

Minimum 141 Requirements: Dual, Instrument
Cross-country
3.5 hours flight
1.0 hours ground instruction



Flight Training

Objective:

For the student to perform the required 250 NM IFR cross-country, demonstrating correct enroute procedures, emergency procedures, and instrument approaches.

Content:

- ___ IFR cross-country planning
- ___ Instrument preflight
- ___ 250 NM cross-country
- ___ Simulated loss of communications
- ___ Simulated engine failure
- ___ Simulated instrument failure
- ___ Simulated radio failure
- ___ Partial panel work
- ___ Precision and non-precision approach—
at different airports
- ___ Postflight procedures

Completion Standards:

This module is complete when the student can conduct the 250 NM IFR cross-country procedures efficiently, in an organized manner, with good communications, while maintaining flight within ± 100 feet, ± 10 degrees, and ± 10 knots and all approaches within specified minimums.

Recommended Reading:

Instrument Flying

Stage 5 / **Module 3**

Date of Completion: _____

Signature: _____

Time Flown: _____

Aircraft _____ **BATD** _____ **Other** _____

Stage 5 / Module 4

Minimum 141 Requirements: Dual, Instrument
1.5 hours flight
1.0 hours ground instruction



Ground Training

Objective:

For the student to have a complete understanding of all areas included in the Instrument Practical Test Standards.

Content:

___ Review the Instrument Practical Test Standards

Assignment:

Review the Instrument Practical Test Standards



Flight Training

Objective:

For the student to practice all instrument procedures in preparation for the checkride.

Content:

- ___ Instrument preflight
- ___ Departure procedures
- ___ Navigation to airway
- ___ Perform 2 holds, 1 partial panel
- ___ Emergency procedures
- ___ VOR full approach
- ___ NDB or GPS approach
- ___ ILS radar vectors approach
- ___ Postflight procedures

Note: Approaches should include straight-in, circle-to-land, and partial panel techniques.

Completion Standards:

This module is complete when the student can perform all instrument procedures within Practical Test Standards and within specified minimums.

Recommended Reading:

Instrument Flying

Instrument Test Prep, Chapters 1 and 2



This lesson may be completed using BATD Lesson 18.
See Appendix 6.

Stage 5 / Module 4
Date of Completion: _____
Signature: _____
Time Flown: _____
Aircraft _____ BATD _____ Other _____

Stage 5 / Module 5 and Stage Check



Ground Training

Objective:

For the student to gain complete understanding of all areas covered in the oral portion of the Instrument checkride.

Content:

- ___ Review all subject matter required for the Instrument rating
- ___ Suggested review material: *Instrument Oral Exam Guide*

Completion Standards:

This lesson is complete when the student passes the Stage 5 Exam with at least an 80%, reconciled to 100%. Student should receive endorsement for FAA instrument written exam.

Assignment:

Suggested reading: Review *Instrument Oral Exam Guide*
Stage 5 Exam
FAA Instrument Rating Knowledge Exam

Minimum 141 Requirements: Dual, Instrument
1.5 hours flight
Stage check
1.5 hours ground instruction
Stage exam



Flight Training

Objective:

For the student to review all instrument procedures in preparation for the checkride. For the Stage Check, student should demonstrate skill in the following areas according to the completion standards.

Content:

- ___ Instrument preflight
- ___ Instrument cockpit check
- ___ File an IFR flight plan
- ___ Compliance with departure, en route, and arrival procedures and clearances
- ___ Departure procedures
- ___ Navigate to airway
- ___ Intercept and track VOR radial
- ___ Intercept and track NDB bearing
- ___ Perform 2 holds, 1 partial panel
- ___ Simulated loss of communications
- ___ Simulated engine failure
- ___ Simulated instrument failure
- ___ Simulated radio failure
- ___ Recover from unusual attitudes
- ___ Steep Turns
- ___ Slow Flight
- ___ VOR approach
- ___ NDB or GPS approach
- ___ ILS approach
- ___ Postflight procedures

Note: Approaches must demonstrate straight-in, circle-to-land, missed approach, partial panel, full and radar vector procedures.

Completion Standards:

This module is complete when the student can demonstrate all instrument maneuvers within practical test standards and approach minimums and conduct the flight unassisted by the flight instructor. Student should receive endorsement for instrument checkride.

Recommended Reading:

Instrument Flying

Stage 5 / Module 5

Date of Completion: _____

Signature: _____

Time Flown: _____

Stage Exam Score: _____

FAA Knowledge Exam Score: _____

Stage Check Successful: _____

Aircraft _____ **BATD** _____ **Other** _____

Optional **Stage 5 Review**



Flight Training

Objective:

For the student to review all Stage 5 tasks and meet all objectives.

Content:

- ___ Instrument preflight
- ___ Instrument cockpit check
- ___ File an IFR flight plan
- ___ Compliance with departure, en route, and arrival procedures and clearances
- ___ Departure procedures
- ___ Navigate to airway
- ___ Intercept and track VOR radial
- ___ Intercept and track NDB bearing
- ___ Perform 2 holds, 1 partial panel
- ___ Simulated loss of communications
- ___ Simulated engine failure
- ___ Simulated instrument failure
- ___ Simulated radio failure
- ___ Recovery from unusual attitudes
- ___ Steep Turns
- ___ Slow Flight
- ___ VOR approach
- ___ NDB or GPS approach
- ___ ILS approach
- ___ Postflight procedures

Note: Approaches must demonstrate straight-in, circle-to-land, missed approach, partial panel, full and radar vector procedures.

Completion Standards:

This module is complete when the student can demonstrate all instrument maneuvers within practical test standards and conduct the flight unassisted by the flight instructor.

Recommended Reading:

Instrument Flying

Optional **Stage 5 Review**

Date of Completion: _____

Signature: _____

Time Flown: _____

Aircraft _____ **BATD** _____ **Other** _____

1. Aeronautical knowledge test: 14 CFR §§61.35(a)(1) and 61.65(a) and (b)

I certify that (First name, MI, Last name) _____
has received the required training of §61.65(b). I have determined that he/she is prepared for the instrument
rating knowledge test.

S/S [date] J.J. Jones 987654321 CFI Exp. 06-30-12

2. Flight proficiency/practical test: 14 CFR §61.65(a)(6)

I certify that (First name, MI, Last name) _____
has received the required training of 14 CFR §61.65(c) and (d). I have determined that he/she is prepared for the
Instrument–Airplane practical test.

S/S [date] J.J. Jones 987654321 CFI Exp. 06-30-12

Confirm for the Checkride:

- Pilot certificate current
- Application form completely filled out
- Logbook and necessary supplies readily accessible
- Materials necessary for planning a cross-country flight
- FAA Knowledge Exam results
- Photo/signature ID
- Medical certificate current
- Instructor endorsements for checkride
- Graduation certificate
- Examiner's fee



U.S. Department
of Transportation
**Federal Aviation
Administration**

FAA Form 8710-1, Airman Certificate and/or Rating Application Supplemental Information and Instructions

Paperwork Reduction Act Statement:

The information collected on this form is necessary to determine applicant eligibility for airman ratings. We estimate it will take 15 minutes to complete this form. The information collected is required to obtain a benefit and becomes part of the Privacy Act system of records DOT/FAA 847, General Air Transportation Records on Individuals. Please note that an agency may not conduct or sponsor, and a person is not required to respond to, a collection of information unless it displays a currently valid OMB control number. The OMB control number associated with this collection is 2120-0021.

Privacy Act

The information on the accompanying form is solicited under authority of Title 14 of the Code of Federal Regulations (14 CFR), Part 61. The purpose of this data is to be used to identify and evaluate your qualifications and eligibility for the issuance of an airman certificate and/or rating. Submission of all requested data is mandatory, except for the Social Security Number (SSN) which is voluntary. Failure to provide all the required information would result in you not being issued a certificate and/or rating. The information would become part of the Privacy Act system of records DOT/FAA 847, General Air Transportation Records on Individuals. The information collected on this form would be subject to the published routine uses of DOT/FAA 847. Those routine uses are: (a) To provide basic airman certification and qualification information to the public upon request. (b) To disclose information to the national Transportation Safety Board (NTSB) in connection with its investigation responsibilities. (c) To provide information about airmen to Federal, state, and local law enforcement agencies when engaged in the investigation and apprehension of drug violators. (d) To provide information about enforcement actions arising out of violations of the Federal Aviation regulations to government agencies, the aviation industry, and the public upon request. (e) To disclose information to another Federal agency, or to a court or an administrative tribunal, when the Government or one of its agencies is a party to a judicial proceeding before the court or involved in administrative proceedings before the tribunal.

Submission of your Social Security Number is voluntary. Disclosure of your SSN will facilitate maintenance of your records which are maintained in alphabetical order and cross-referenced with your SSN and airman certificate number to provide prompt access. In the event of nondisclosure, a unique number will be assigned to your file.

See Privacy Act Information above. Detach this part before submitting form.

Instructions for completing this form (FAA 8710-1) are on the reverse.

If an electronic form is not printed on a duplex printer, the applicant's name, date of birth, and certificate number (if applicable) must be furnished on the reverse side of the application. This information is required for identification purposes. The telephone number and E-mail address are optional.

Tear off this cover sheet before submitting this form.

AIRMAN CERTIFICATE AND/OR RATING APPLICATION
INSTRUCTIONS FOR COMPLETING FAA FORM 8710-1

I. APPLICATION INFORMATION. *Check appropriate block(s).*

Block A. Name. Enter legal name. Use no more than one middle name for record purposes. Do not change the name on subsequent applications unless it is done in accordance with 14 CFR Section 61.25. If you do not have a middle name, enter "NMN". If you have a middle initial only, indicate "Initial only." If you are a Jr., or a II, or III, so indicate. If you have an FAA certificate, the name on the application should be the same as the name on the certificate unless you have had it changed in accordance with 14 CFR Section 61.25.

Block B. Social Security Number. Optional: See supplemental Information Privacy Act. Do not leave blank: Use only **US Social Security Number**. Enter either "SSN" or the words "Do not Use" or "None." SSN's are not shown on certificates.

Block C. Date of Birth. Check for accuracy. Enter eight digits; Use numeric characters, i.e., 07-09-1925 instead of July 9, 1925. Check to see that DOB is the same as it is on the medical certificate.

Block D. Place of Birth. If you were born in the USA, enter the city and state where you were born. If the city is unknown, enter the county and state. If you were born outside the USA, enter the name of the city and country where you were born.

Block E. Permanent Mailing Address. Enter residence number and street, P.O. Box or rural route number in the top part of the block above the line. The City, State, and ZIP code go in the bottom part of the block below the line. Check for accuracy. Make sure the numbers are not transposed. FAA policy requires that you use your permanent mailing address.

Justification must be provided on a separate sheet of paper signed and submitted with the application when a PO Box or rural route number is used in place of your permanent physical address. A map or directions must be provided if a physical address is unavailable.

Block F. Citizenship. Check USA if applicable. If not, enter the country where you are a citizen.

Block G. Do you read, speak, write and understand the English language? Check yes or no.

Block H. Height. Enter your height in inches. Example: 5'8" would be entered as 68 in. No fractions, use whole inches only.

Block I. Weight. Enter your weight in pounds. No fractions, use whole pounds only.

Block J. Hair. Spell out the color of your hair. If bald, enter "Bald." Color should be listed as black, red, brown, blond, or gray. If you wear a wig or toupee, enter the color of your hair under the wig or toupee.

Block K. Eyes. Spell out the color of your eyes. The color should be listed as blue, brown, black, hazel, green, or gray.

Block L. Sex. Check male or female.

Block M. Do You Now Hold or Have You Ever Held An FAA Pilot Certificate? Check yes or no. (NOTE: A student pilot certificate is a "Pilot Certificate.")

Block N. Grade of Pilot Certificate. Enter the grade of pilot certificate (i.e., Student, Recreational, Private, Commercial, or ATP). Do NOT enter flight instructor certificate information.

Block O. Certificate Number. Enter the number as it appears on your pilot certificate.

Block P. Date Issued. Enter the date your pilot certificate was issued.

Block Q. Do You Now Hold A Medical Certificate? Check yes or no. If yes, complete Blocks R, S, and T.

Block R. Class of Certificate. Enter the class as shown on the medical certificate, i.e., 1st, 2nd, or 3rd class.

Block S. Date Issued. Enter the date your medical certificate was issued.

Block T. Name of Examiner. Enter the name as shown on medical certificate.

Block U. Narcotics, Drugs. Check appropriate block. Only check "Yes" if you have actually been convicted. If you have been charged with a violation which has not been adjudicated, check "No".

Block V. Date of Final Conviction. If block "U" was checked "Yes" give the date of final conviction.

II. CERTIFICATE OR RATING APPLIED FOR ON BASIS OF:

Block A. Completion of Required Test.

1. AIRCRAFT TO BE USED. (If flight test required) – Enter the make and model of each aircraft used. If simulator or FTD, indicate.
2. TOTAL TIME IN THIS AIRCRAFT (Hrs.) – (a) Enter the total Flight Time in each make and model. (b) Pilot-In-Command Flight Time - In each make and model.

Block B. Military Competence Obtained In. Enter your branch of service, date rated as a military pilot, your rank, or grade and service number. In block 4a or 4b, enter the make and model of each military aircraft used to qualify (as appropriate).

Block C. Graduate of Approved Course.

1. NAME AND LOCATION OF TRAINING AGENCY/CENTER. As shown on the graduation certificate. Be sure the location is entered.
2. AGENCY SCHOOL/CENTER CERTIFICATION NUMBER. As shown on the graduation certificate. Indicate if 142 training center.
3. CURRICULUM FROM WHICH GRADUATED. As shown on the graduation certificate.
4. DATE. Date of graduation from indicated course. Approved course graduate must also complete Block "A" COMPLETION OF REQUIRED TEST.

Block D. Holder of Foreign License Issued By.

1. COUNTRY. Country which issued the license.
2. GRADE OF LICENSE. Grade of license issued, i.e., private, commercial, etc.
3. NUMBER. Number which appears on the license.
4. RATINGS. All ratings that appear on the license.

Block E. Completion of Air Carrier's Approved Training Program.

1. Name of Air Carrier.
2. Date program was completed.
3. Identify the Training Curriculum.

III. RECORD OF PILOT TIME. The minimum pilot experience required by the appropriate regulation must be entered. It is recommended, however, that ALL pilot time be entered. If decimal points are used, be sure they are legible. Night flying must be entered when required. You should fill in the blocks that apply and ignore the blocks that do not. Second In Command "SIC" time used may be entered in the appropriate blocks. Flight Simulator, Flight Training Device and PCATD time may be entered in the boxes provided. Total, Instruction received, and Instrument Time should be entered in the top, middle, or bottom of the boxes provided as appropriate.

IV. HAVE YOU FAILED A TEST FOR THIS CERTIFICATE OR RATING? Check appropriate block.

V. APPLICANT'S CERTIFICATION.

- A. SIGNATURE. The way you normally sign your name.
- B. DATE. The date you sign the application.



DEPARTMENT OF TRANSPORTATION
FEDERAL AVIATION ADMINISTRATION

Airman Certificate and/or Rating Application

I Application Information

Student Recreational Private Commercial Airline Transport Instrument
 Additional Rating Airplane Single-Engine Airplane Multiengine Rotorcraft Balloon Airship Glider Powered-Lift
 Flight Instructor _____ Initial _____ Renewal _____ Reinstatement Additional Instructor Rating Ground Instructor Other _____
 Medical Flight Test Reexamination Reissuance of _____ certificate

A. Name (Last, First, Middle) _____ **B. SSN (US Only)** _____ **C. Date of Birth** _____ **D. Place of Birth** _____

E. Address _____ **F. Citizenship** _____ Specify _____ **G. Do you read, speak, write, & understand the English language?** Yes No

City, State, Zip Code _____ **H. Height** _____ **I. Weight** _____ **J. Hair** _____ **K. Eyes** _____ **L. Sex** Male Female

M. Do you now hold, or have you ever held an FAA Pilot Certificate? Yes No **N. Grade Pilot Certificate** _____ **O. Certificate Number** _____ **P. Date Issued** _____

Q. Do you hold a Medical Certificate? Yes No **R. Class of Certificate** _____ **S. Date Issued** _____ **T. Name of Examiner** _____

U. Have you ever been convicted for violation of any Federal or State statutes relating to narcotic drugs, marijuana, or depressant or stimulant drugs or substances? Yes No **V. Date of Final Conviction** _____

II. Certificate or Rating Applied For on Basis of:

A. Completion of Required Test

1. Aircraft to be used (if flight test required) _____ **2a. Total time in this aircraft / SIM / FTD** _____ **2b. Pilot in command** _____

hours _____ hours _____

B. Military Competence Obtained In

1. Service _____ **2. Date Rated** _____ **3. Rank or Grade and Service Number** _____

4a. Flown 10 hours PIC in last 12 months in the following Military Aircraft. _____ **4b. US Military PIC & Instrument check in last 12 months (List Aircraft)** _____

C. Graduate of Approved Course

1. Name and Location of Training Agency or Training Center _____ **1a. Certification Number** _____

2. Curriculum From Which Graduated _____ **3. Date** _____

D. Holder of Foreign License Issued By

1. Country _____ **2. Grade of License** _____ **3. Number** _____

4. Ratings _____

E. Completion of Air Carrier's Approved Training Program

1. Name of Air Carrier _____ **2. Date** _____ **3. Which Curriculum** _____

Initial Upgrade Transition

III RECORD OF PILOT TIME (Do not write in the shaded areas.)

	Total	Instruction Received	Solo	Pilot in Command (PIC)	Cross Country Instruction Received	Cross Country Solo	Cross Country PIC	Instrument	Night Instruction Received	Night Take-off/Landings	Night PIC	Night Take-Off/Landing PIC	Number of Flights	Number of Aero-Tows	Number of Ground Launches	Number of Powered Launches
Airplanes				PIC			PIC				PIC	PIC				
				SIC			SIC				SIC	SIC				
Rotorcraft				PIC			PIC				PIC	PIC				
				SIC			SIC				SIC	SIC				
Powered Lift				PIC			PIC				PIC	PIC				
				SIC			SIC				SIC	SIC				
Gliders																
Lighter Than Air																
Simulator Training Device																
PCATD																

IV. Have you failed a test for this certificate or rating? Yes No

V. Applicant's Certification -- I certify that all statements and answers provided by me on this application form are complete and true to the best of my knowledge and I agree that they are to be considered as part of the basis for issuance of any FAA certificate to me. I have also read and understand the Privacy Act statement that accompanies this form.

Signature of Applicant _____ **Date** _____

Instructor's Recommendation			
I have personally instructed the applicant and consider this person ready to take the test.			
Date	Instructor's Signature (Print Name & Sign)	Certificate No:	Certificate Expires
Air Agency's Recommendation			
The applicant has successfully completed our _____ course, and is recommended for certification or rating without further _____ test.			
Date	Agency Name and Number	Officials Signature	
		Title	
Designated Examiner or Airman Certification Representative Report			
<input type="checkbox"/> Student Pilot Certificate Issued (Copy attached) <input type="checkbox"/> I have personally reviewed this applicant's pilot logbook and/or training record, and certify that the individual meets the pertinent requirements of 14 CFR Part 61 for the certificate or rating sought. <input type="checkbox"/> I have personally reviewed this applicant's graduation certificate, and found it to be appropriate and in order, and have returned the certificate. <input type="checkbox"/> I have personally tested and/or verified this applicant in accordance with pertinent procedures and standards with the result indicated below. <input type="checkbox"/> Approved -- Temporary Certificate Issued (Original Attached) <input type="checkbox"/> Disapproved -- Disapproval Notice Issued (Original Attached)			
Location of Test (Facility, City, State)		Duration of Test	
		Ground	Simulator/FTD
		Flight	
Certificate or Rating for Which Tested		Type(s) of Aircraft Used	Registration No.(s)
Date	Examiner's Signature (Print Name & Sign)	Certificate No.	Designation No.
			Designation Expires
Evaluator's Record (Use For ATP Certificate and/or Type Ratings)			
	Inspector	Examiner	Signature and Certificate Number
			Date
Oral	<input type="checkbox"/>	<input type="checkbox"/>	_____
Approved Simulator/Training Device Check	<input type="checkbox"/>	<input type="checkbox"/>	_____
Aircraft Flight Check	<input type="checkbox"/>	<input type="checkbox"/>	_____
Advanced Qualification Program	<input type="checkbox"/>	<input type="checkbox"/>	_____
Aviation Safety Inspector or Technician Report			
I have personally tested this applicant in accordance with or have otherwise verified that this applicant complies with pertinent procedures, standards, policies, and or necessary requirements with the result indicated below.			
<input type="checkbox"/> Approved -- Temporary Certificate Issued (Original Attached) <input type="checkbox"/> Disapproved -- Disapproval Notice Issued (Original Attached)			
Location of Test (Facility, City, State)		Duration of Test	
		Ground	Simulator/FTD
		Flight	
Certificate or Rating for Which Tested		Type(s) of Aircraft Used	Registration No.(s)
<input type="checkbox"/> Student Pilot Certificate Issued <input type="checkbox"/> Certificate or Rating Based on <input type="checkbox"/> Flight Instructor <input type="checkbox"/> Ground Instructor <input type="checkbox"/> Examiner's Recommendation <input type="checkbox"/> Military Competence <input type="checkbox"/> Renewal <input type="checkbox"/> Accepted <input type="checkbox"/> Rejected <input type="checkbox"/> Foreign License <input type="checkbox"/> Reinstatement <input type="checkbox"/> Reissue or Exchange of Pilot Certificate <input type="checkbox"/> Approved Course Graduate <input type="checkbox"/> Instructor Renewal Based on <input type="checkbox"/> Special Medical test conducted -- report forwarded to Aeromedical Certification Branch, AAM-330 <input type="checkbox"/> Other Approved FAA Qualification Criteria <input type="checkbox"/> Activity <input type="checkbox"/> Training Course <input type="checkbox"/> Test <input type="checkbox"/> Duties and Responsibilities			
Training Course (FIRC) Name		Graduation Certificate No.	Date
Date	Inspector's Signature (Print Name & Sign)	Certificate No.	FAA District Office
Attachments: <input type="checkbox"/> Airman's Identification (ID)			
<input type="checkbox"/> Student Pilot Certificate (Copy)	Form of ID _____	ID: _____	Name: _____
<input type="checkbox"/> Knowledge Test Report	Number _____	Date of Birth: _____	
<input type="checkbox"/> Temporary Airman Certificate	Expiration Date _____	Certificate Number: _____	
<input type="checkbox"/> Notice of Disapproval	Telephone Number _____	E-Mail Address _____	
<input type="checkbox"/> Superseded Airman Certificate			

Stage 1 Exam

Instrument Flight

Name: _____

Grade: _____ Date: _____

Instructor: _____

Circle the most correct answer choice.

1. How many hours are required for completion of the Instrument Rating, following a Part 141 program?
 - A —35 hours of flight training, 30 hours of ground training.
 - B —40 hours of flight training, 35 hours of ground training.
 - C —73 hours of flight training, 40 hours of ground training.
2. What must be completed before the student can move on to the next Module?
 - A —Student must complete the review questions following each reading assignment.
 - B —Student must meet the objective specified for each module.
 - C —Both A and B.
3. In order for students to succeed in this Part 141 program
 - A —all objectives must be met for each module, homework completed, and Stage Exams passed with at least an 80%.
 - B —all objectives must be met for each module.
 - C —all objectives must be met for each module, homework completed, and Stage Exams passed with at least a 70%.
4. What are the three fundamental skills involved in attitude instrument flying?
 - A —Instrument interpretation, trim application, and aircraft control.
 - B —Cross-check, instrument interpretation, and aircraft control.
 - C —Cross-check, emphasis, and aircraft control.
5. Eye movement radiating out and back to selected instruments is known as the
 - A —circular scan.
 - B —basic-T scan.
 - C —selective radial scan.
6. If you are departing from an airport where you cannot obtain an altimeter setting, you should:
 - A —set 29.92 in. Hg in the pressure window of the altimeter.
 - B —set the altimeter to read field elevation.
 - C —set the altimeter to read zero.
7. As you roll into a standard-rate turn to the left from an easterly heading in the northern hemisphere, the magnetic compass will indicate:
 - A —the approximate correct magnetic heading if the roll into the turn is smooth.
 - B —due east for a short time, then gradually catch up with the heading of the aircraft.
 - C —a turn to the right, but at a slower rate than is actually occurring.
8. As power is reduced to change airspeed from high to low cruise in level flight, which instrument is primary for pitch?
 - A —Attitude indicator.
 - B —Vertical speed indicator.
 - C —Altimeter.
9. What tolerances must be maintained to perform instrument straight-and-level flight according to the Instrument Practical Test Standards?
 - A —Altitude must be maintained ± 100 feet, heading $\pm 10^\circ$, and airspeed ± 10 knots.
 - B —Altitude must be maintained ± 150 feet, heading $\pm 15^\circ$, and airspeed ± 15 knots.
 - C —Altitude must be maintained ± 100 feet, heading $\pm 15^\circ$, and airspeed ± 15 knots.
10. To enter a climb at the same speed at which the airplane is flying level:
 - A —raise the nose first, and then add power.
 - B —add power and raise the nose simultaneously.
 - C —add power first, and then raise the nose.

-
- 11.** Approximately what percentage of the indicated vertical speed should be used to determine the number of feet to lead the level-off from a climb or descent to a specific altitude?
- A —20%.
 - B —10%.
 - C —50%.
- 12.** If a standard rate turn is maintained, how much time would be required to turn to the left from a heading of 090° to a heading of 300°?
- A —30 seconds.
 - B —40 seconds.
 - C —50 seconds.
- 13.** The primary reason the angle of attack must be increased, to maintain a constant altitude during a coordinated turn, is because the
- A —thrust is acting in a different direction, causing a reduction in airspeed and loss of lift.
 - B —vertical component of lift has decreased as the result of the bank.
 - C —use of ailerons has increased the drag.
- 14.** What is the correct sequence for recovery from a spiraling, nose-low, increasing airspeed, unusual flight attitude?
- A —Increase pitch attitude, reduce power, and level wings.
 - B —Reduce power, correct the bank attitude, and raise the nose to a level attitude.
 - C —Reduce power, raise the nose to level attitude, and correct the bank attitude.
- 15.** During recoveries from unusual attitudes, level flight is attained the instant
- A —the horizon bar on the attitude indicator is exactly overlapped with the miniature airplane.
 - B —a zero rate of climb is indicated on the VSI.
 - C —the altimeter and airspeed needles stop prior to reversing their direction of movement.
- 16.** The heading indicator is inoperative. What is the primary bank instrument in unaccelerated level flight on a specific heading?
- A —Magnetic compass.
 - B —Attitude indicator.
 - C —Turn coordinator.
- 17.** Which instrument provides the most pertinent information (primary) for pitch correction requirements in straight-and-level flight?
- A —Vertical speed indicator.
 - B —Altimeter.
 - C —Attitude indicator.
- 18.** What instrument indication should a pilot observe if an airspeed indicator ram air input and drain hole are blocked?
- A —The airspeed indicator will react as an altimeter.
 - B —The airspeed indicator will show a decrease with an increase in altitude.
 - C —No airspeed indicator change will occur during climbs or descents.
- 19.** Which data must be recorded in the aircraft log or other appropriate log by a pilot making a VOR operational check for IFR operations?
- A —VOR name or identification, date of check, amount of bearing error, and signature.
 - B —Place of operational check, amount of bearing error, date of check, and signature.
 - C —Date of check, VOR name or identification, place of operational check, and amount of bearing error.
- 20.** Who is responsible for determining that the altimeter system has been checked and found to meet regulatory requirements for a particular instrument flight?
- A —Owner.
 - B —Operator.
 - C —Pilot-in-command.
- 21.** Which checks and inspections of flight instruments or instrument systems must be accomplished before an aircraft can be flown under IFR?
- A —VOR within 30 days, altimeter systems within 24 calendar months, and transponder within 24 calendar months.
 - B —ELT test within 30 days, altimeter systems within 12 calendar months, and transponder within 24 calendar months.
 - C —VOR within 24 calendar months, transponder within 24 calendar months, and altimeter system within 12 calendar months.

- 22.** What minimum navigation equipment is required for IFR flight?
- A —VOR/LOC receiver, transponder, and DME.
 - B —VOR receiver and, if in ARTS III environment, a coded transponder equipped for altitude reporting.
 - C —Navigation equipment appropriate to the ground facilities to be used.
- 23.** How should you preflight check the altimeter prior to an IFR flight?
- A —Set the altimeter to 29.92" Hg. With current temperature and the altimeter indication, determine the true altitude to compare with the field elevation.
 - B —Set the altimeter first with 29.92" Hg and then the current altimeter setting. The change in altitude should correspond to the change in setting.
 - C —Set the altimeter to the current altimeter setting. The indication should be within 75 feet of the actual elevation for acceptable accuracy.
- 24.** According to the Instrument Practical Test Standards, a steep turn must be performed maintaining
- A —a coordinated 360° turn (both left and right), with an approximate 45° bank, ±5 degrees, rolling out on the entry heading, ±10°.
 - B —a 50° bank, ±10°, while coordinating a 360° turn.
 - C —±100 feet, ±10 knots, ±10° of bank, and coordination.
- 25.** What is the primary pitch instrument when establishing a constant-attitude standard rate turn?
- A —Altimeter.
 - B —VSI.
 - C —Airspeed indicator.
- 26.** Before beginning any flight under IFR, the pilot-in-command must become familiar with all available information concerning that flight. In addition, the pilot must
- A —list an alternate airport on the flight plan and become familiar with the instrument approaches to that airport.
 - B —list an alternate airport on the flight plan and confirm adequate takeoff and landing performance at the destination airport.
 - C —be familiar with the runway lengths at airports of intended use, and the alternatives available if the flight cannot be completed.
- 27.** During a constant-bank level turn, what effect would an increase in airspeed have on the rate and radius of turn?
- A —Rate of turn would increase, and radius of turn would increase.
 - B —Rate of turn would decrease, and radius of turn would decrease.
 - C —Rate of turn would decrease, and radius of turn would increase.
- 28.** What instruments are primary for pitch, bank, and power, respectively, when transitioning into a constant airspeed climb from straight-and-level flight?
- A —Attitude indicator, heading indicator, and manifold pressure gauge or tachometer.
 - B —Attitude indicator for both pitch and bank; airspeed indicator for power.
 - C —Vertical speed, attitude indicator, and manifold pressure or tachometer.

Stage 2 Exam

Navigation

Name: _____

Grade: _____ Date: _____

Instructor: _____

Circle the most correct answer choice.

1. What approximate rate of descent in fpm is required to achieve a 3° glideslope, which is 300 feet per NM, if the groundspeed of the airplane is 90 knots?
A —300 fpm.
B —450 fpm.
C —550 fpm.
2. The approximate range of any VHF signals for an airplane 2,000 feet above the level of a ground station is
A —45 NM.
B —61 NM.
C —55 NM.
3. If a radar service is not available, then ATC will separate airplanes using procedures based on their estimated positions and known altitudes. This is known as:
A —procedural separation.
B —nonradar separation.
C —standby separation.
4. FAA radar locations are found in the
A —Aeronautical Information Manual.
B —Airport/Facility Directory.
C —Low Altitude Enroute Chart legend.
5. The coded identifier of the DME is transmitted about once every
A —30 seconds.
B —10 seconds.
C —45 seconds.
6. If an airplane tracking directly toward a DME is at 37 DME at time: 0115, and at 27 DME at time: 0120, what is its groundspeed?
A —120 kts.
B —86 kts.
C —140 kts.
7. (Refer to instruments in Exam Figure 1, below.) On the basis of this information, the magnetic bearing TO the station would be
A — 175° .
B — 255° .
C — 355° .
8. If an airplane steering MH 250 has a reading of 030 on its relative bearing indicator, what is the magnetic bearing of the airplane FROM the NDB?
A —MB 280 from the NDB.
B —MB 100 from the NDB.
C —MB 080 from the NDB.

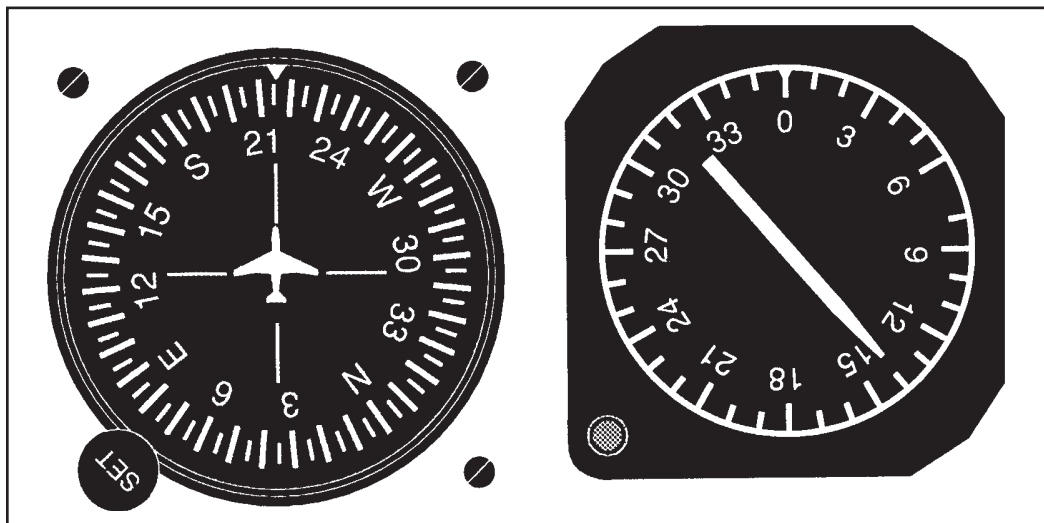

Exam Figure 1. Directional Gyro and ADF indicator

- 9.** On MH 020 with RB 355, the MB to the NDB is
A —MB 015 to NDB.
B —MB 020 to NDB.
C —MB 025 to NDB.
- 10.** MH 080; RBI 000. What heading would you steer to make a 90° intercept of a course of MC 040 to the NDB?
A —Left turn to MH 130.
B —Right turn to MH 130.
C —Right turn to MH 310.
- 11.** If the head of the RMI needle reads RMI 070, the magnetic bearing from the ground station to the airplane is
A —MB 250 from ground station.
B —MB 070 from ground station.
C —MB 355 from ground station.
- 12.** The desired course is MC 120 outbound from an NDB or VOR. The WCA is 3° left. The airplane is achieving this course when the head of the RMI needle indicates
A —RMI 120.
B —RMI 300.
C —RMI 310.
- 13.** A 5-dot deviation of the CDI on the VOR cockpit display indicates a displacement of _____ from the selected course
A —10° or more
B —5° or more
C —12° or more
- 14.** If the CDI is centered with 090 set on the OBI, and the TO flag is showing, what radial is the airplane on?
A —135 radial.
B —090 radial.
C —270 radial.
- 15.** If two components of an ILS are unusable, the appropriate minimum to use is:
A —the highest minimum required by any single component that is unusable.
B —the same minimum for the fully operational ILS.
C —the normal minimum plus 100 feet.
- 16.** Minimums for an ILS approach with all components operative normally establish a DH with a HAT of
A —800 feet.
B —500 feet.
C —200 feet.
- 17.** By which means may a pilot determine if a Loran C equipped aircraft is approved for IFR operations?
A —Not necessary; Loran C is not approved for IFR.
B —Check aircraft logbook.
C —Check in the Airplane Flight Manual Supplement.
- 18.** When using GPS for navigation and instrument approaches, any required alternate airport must have
A —authorization to fly approaches under IFR using GPS avionics systems.
B —a GPS approach that is anticipated to be operational and available at the ETA.
C —an approved operational instrument approach procedure other than GPS.
- 19.** How can a pilot determine if a Global Positioning System (GPS) installed in an aircraft is approved for IFR enroute and IFR approaches?
A —Flight manual supplement.
B —GPS operator's manual.
C —Aircraft owner's handbook.
- 20.** (Refer to Exam Figure 2, Page 2-3.) Which OBS selection on the No. 2 NAV would center the CDI and change the ambiguity indication to a TO?
A —166°.
B —346°.
C —354°.
- 21.** When is an IFR flight plan required?
A —When less than VFR conditions exist in either Class E or Class G airspace, and in Class A airspace.
B —In all Class E airspace when conditions are below VFR, in Class A airspace, and in defense zone airspace.
C —In Class E airspace when IMC exists, or in Class A airspace.
- 22.** Prior to which operation must an IFR flight plan be filed and an appropriate ATC clearance received?
A —Flying by reference to instruments in controlled airspace.
B —Entering controlled airspace when IMC exists.
C —Takeoff when IFR weather conditions exist.

FREQ	N.M.	KNOTS	MIN
115.0	60.0	180	20.0

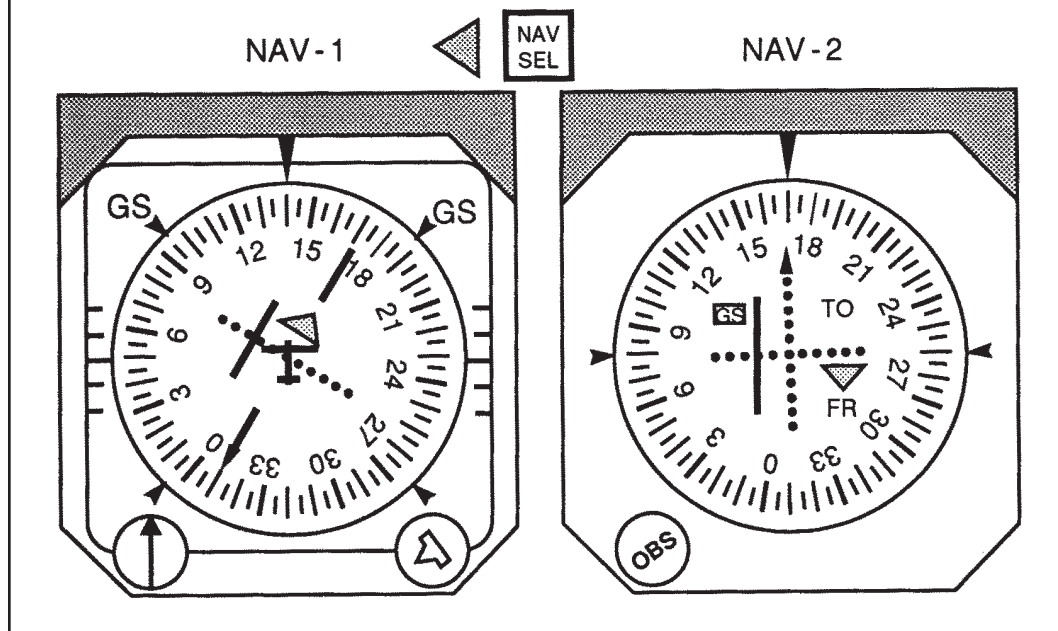

Exam Figure 2. No. 1 and No. 2 NAV presentation

- 23.** VOR station passage is indicated by
- A —the first positive, complete reversal of the TO-FROM indicator.
 - B —the moment the TO-FROM indicator becomes blank.
 - C —the first full-scale deflection of the CDI.
- 24.** Determine the approximate time and distance to a station if a 5° wing-tip bearing change occurs in 1.5 minutes with a true airspeed of 95 knots.
- A —16 minutes and 14.3 NM.
 - B —18 minutes and 28.5 NM.
 - C —18 minutes and 33.0 NM.
- 25.** A particular VOR station is undergoing routine maintenance. This is evidenced by
- A —removal of the navigational feature.
 - B —broadcasting a maintenance alert signal on the voice channel.
 - C —removal of the identification feature.
- 26.** You wish to track MC 030 in no-wind conditions. What magnetic heading would you steer?
- A —MH 030.
 - B —MH 210.
 - C —MH 120.
- 27.** Current charts must be used at all times. Low Altitude Enroute charts are revised
- A —every 56 days.
 - B —no more than once a year.
 - C —every 6 months.

Stage 3 Exam

Holding Procedures

Name: _____

Grade: _____ Date: _____

Instructor: _____

Circle the most correct answer choice.

- The shape of a typical holding pattern is a
 - rectangle.
 - racetrack.
 - ellipse.
- (Refer to Exam Figure 1, Page 3-3.) You receive this ATC clearance:
“... cleared to the XYZ VORTAC. Hold north on the three six zero radial, left turns...”
What is the recommended procedure to enter the holding pattern?
 - Parallel only.
 - Direct only.
 - Teardrop only.
- A procedure turn should normally be completed within ____ NM of the procedure turn fix, or as otherwise published on the instrument approach chart.
 - 10 NM
 - 20 NM
 - 5 NM
- When the approach procedure involves a procedure turn, the maximum speed should not be greater than
 - 180 knots IAS.
 - 200 knots IAS.
 - 250 knots IAS.
- To maintain a right-hand DME arc with a right crosswind component, the bearing pointer should be
 - on the right wingtip.
 - ahead of the right wingtip.
 - behind the right wingtip.
- For each $\frac{1}{2}$ NM you have drifted outside a DME arc, a suitable heading change is approximately
 - 10-20 degrees away from the arc.
 - 10-20 degrees toward the arc.
 - 5-10 degrees away from the arc.
- The minimum instrument time required, within the last 6 months, to be current for IFR is
 - 6 approaches, holding procedures, and intercepting and tracking courses through the use of navigation systems.
 - 6 hours in the same category aircraft.
 - 6 hours in the same category aircraft, and at least 3 of the 6 hours in actual conditions.
- Which flight time may be logged as instrument time when on an instrument flight plan?
 - All of the time the aircraft was not controlled by ground references.
 - Only the time you controlled the aircraft solely by reference to flight instruments.
 - Only the time you were flying in IFR weather conditions.
- When departing in IMC conditions from an airport located in Class G airspace, you must file a flight plan and receive an ATC clearance before:
 - takeoff.
 - entering IFR conditions.
 - entering controlled airspace.
- You are in IMC and have two-way radio communications failure. If you do not exercise emergency authority, what procedure are you expected to follow?
 - Set transponder to code 7600, continue flight on assigned route and fly at the last assigned altitude or the MEA, whichever is higher.
 - Set transponder to code 7700 for 1 minute, then to 7600, and fly to an area with VFR weather conditions.
 - Set transponder to 7700 and fly to an area where you can let down in VFR conditions.
- Which condition is guaranteed for all of the following altitude limits: MAA, MCA, MRA, MOCA, and MEA (Non-mountainous area.)
 - Adequate navigation signals.
 - Adequate communications.
 - 1,000-foot obstacle clearance.

- 12.** What is the definition of MEA?
- A —The lowest published altitude which meets obstacle clearance requirements and assures acceptable navigational signal coverage.
 - B —The lowest published altitude which meets obstacle requirements, assures acceptable navigational signal coverage, two-way radio communications, and provides adequate radar coverage.
 - C —An altitude which meets obstacle clearance requirements, assures acceptable navigation signal coverage, two-way radio communications, adequate radar coverage, and accurate DME mileage.
- 13.** What is an operational consideration if you fly into rain which freezes on impact?
- A —You have flown into an area of thunderstorms.
 - B —Temperatures are above freezing at some higher altitude.
 - C —You have flown through a cold front.
- 14.** Test data indicate that ice, snow, or frost on the leading edge and upper surface of a wing, having a thickness and roughness similar to medium or course sandpaper can
- A —reduce lift by as much as 50 percent and increase drag by as much as 50 percent.
 - B —increase drag and reduce lift by as much as 25 percent.
 - C —reduce lift by as much as 30 percent and increase drag by 40 percent.
- 15.** What condition is most conducive to the formation of radiation fog?
- A —Warm, moist air over low, flatland areas on clear, calm nights.
 - B —Moist, tropical air moving over cold, offshore water.
 - C —The movement of cold air over much warmer water.
- 16.** Under which condition does advection fog usually form?
- A —Moist air moving over colder ground or water.
 - B —Warm, moist air settling over a cool surface under no-wind conditions.
 - C —A land breeze blowing a cold air mass over a warm water current.
- 17.** (Refer to Exam Figure 2, Page 3-3.) You receive this ATC clearance:
- “...cleared to the XYZ NDB. Hold northeast on the zero four zero degree bearing from the NDB. Left turns...”
- At station passage you note the indications in Figure 2. What is the recommended procedure to enter the holding pattern?
- A —Direct only.
 - B —Teardrop only.
 - C —Parallel only.
- 18.** What timing procedure should be used when performing a holding pattern at a VOR?
- A —Timing for the outbound leg begins over or abeam the VOR, whichever occurs later.
 - B —Timing for the inbound leg begins when initiating the turn inbound.
 - C —Adjustments in timing of each pattern should be made on the inbound leg.
- 19.** When holding at an NDB, at what point should the timing begin for the second leg outbound?
- A —When the wings are level and the wind drift correction angle is established after completing the turn to the outbound heading.
 - B —When the wings are level after completing the turn to the outbound heading, or abeam the fix, whichever occurs first.
 - C —When abeam the holding fix.
- 20.** At what point should the timing begin for the first leg outbound in a nonstandard holding pattern?
- A —Abeam the holding fix, or wings level, whichever occurs last.
 - B —When the wings are level at the completion of the 180° turn outbound.
 - C —When abeam the holding fix.
- 21.** When more than one circuit of the holding pattern is needed to lose altitude or become better established on course, the additional circuits can be made
- A —at pilot’s discretion.
 - B —only in an emergency.
 - C —only if pilot advises ATC.

- 22.** If during a VFR practice instrument approach, Radar Approach Control assigns an altitude or heading that will cause you to enter the clouds, what action should be taken?
- A —Enter the clouds, since ATC authorization for practice approaches is considered an IFR clearance.
 - B —Avoid the clouds and inform ATC that altitude/heading will not permit VFR.
 - C —Abandon the approach.

- 23.** What does declaring “minimum fuel” to ATC imply?
- A —Traffic priority is needed to the destination airport.
 - B —Emergency handling is required to the nearest usable airport.
 - C —Merely an advisory that indicates an emergency situation is possible should any undue delay occur.

- 24.** Which clearance items are always given in an abbreviated IFR departure clearance? (Assume radar environment.)
- A —Altitude, destination airport, and one or more fixes which identify the initial route of flight.
 - B —Destination airport, altitude, and DP Name-Number-Transition, if appropriate.
 - C —Clearance limit, and DP Name, Number, and/or Transition, if appropriate.

- 25.** What are the minimum fuel requirements for airplanes in IFR conditions, if the first airport of intended landing is forecast to have a 1,500-foot ceiling and 3 miles visibility at flight-planned ETA? Fuel to fly to the first airport of intended landing,
- A —and fly thereafter for 45 minutes at normal cruising speed.
 - B —fly to the alternate, and fly thereafter for 45 minutes at normal cruising speed.
 - C —fly to the alternate, and fly thereafter for 30 minutes at normal cruising speed.

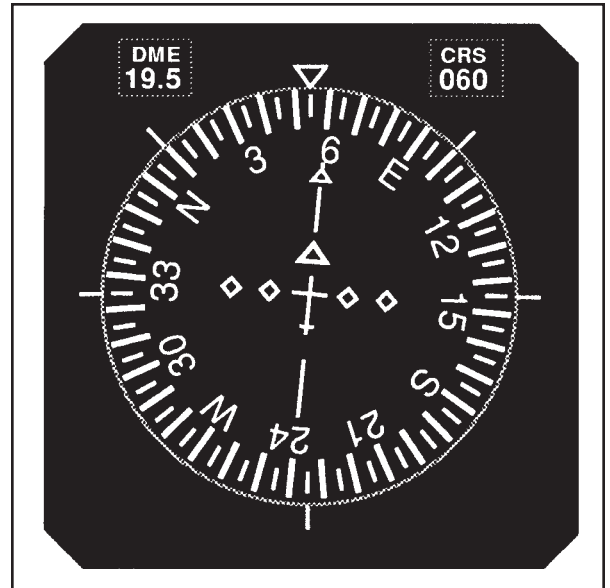

Exam Figure 1. Aircraft course and DME indicator

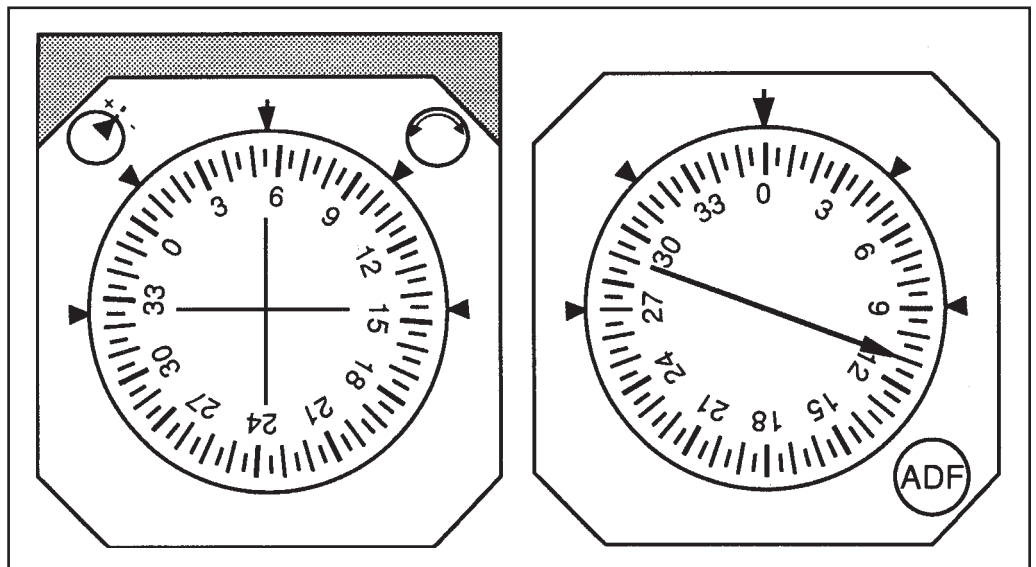

Exam Figure 2. Heading and ADF indicator

Stage 4 Exam

Instrument Approaches

Name: _____

Grade: _____ Date: _____

Instructor: _____

Circle the most correct answer choice.

1. How can an IAF be identified on a Standard Instrument Approach Procedure (SIAP) Chart?
 - A —The procedure turn and the fixes labeled IAF where no procedure turn is authorized.
 - B —Any fix illustrated within the 10-mile ring other than the FAF or stepdown fix.
 - C —The procedure turn and the fixes on the feeder facility ring.
2. During an instrument precision approach, terrain and obstacle clearance depends on adherence to
 - A —minimum altitude shown on the IAP.
 - B —terrain contour information.
 - C —natural and man-made reference point information.
3. Standard takeoff minimums are stated as
 - A —visibility.
 - B —cloud ceiling.
 - C —both A and B.
4. To accept a DP you must have with you in the cockpit at least
 - A —a textual description.
 - B —a diagram.
 - C —a textual description and a diagram.
5. You should circle-to-land at the
 - A —decision height.
 - B —circling MDA.
 - C —straight-in MDA.
6. If the pilot loses visual reference while circling to land from an instrument approach and ATC radar service is not available, the missed approach action should be to
 - A —execute a climbing turn to parallel the published final approach course and climb to the initial approach altitude.
 - B —climb to the published circling minimums then proceed direct to the final approach fix.
 - C —make a climbing turn toward the landing runway and continue the turn until established on the missed approach course.
7. What determines the structure or type of clouds which form as a result of air being forced to ascend?
 - A —The method by which the air is lifted.
 - B —The stability of the air before lifting occurs.
 - C —The amount of condensation nuclei present after lifting occurs.
8. Steady precipitation, in contrast to showers, preceding a front is an indication of
 - A —stratiform clouds with moderate turbulence.
 - B —cumuliform clouds with little or no turbulence.
 - C —stratiform clouds with little or no turbulence.
9. What are the requirements for the formation of a thunderstorm?
 - A —A cumulus cloud with sufficient moisture.
 - B —A cumulus cloud with sufficient moisture and an inverted lapse rate.
 - C —Sufficient moisture, an unstable lapse rate, and a lifting action.
10. What procedure is recommended if a pilot should unintentionally penetrate embedded thunderstorm activity?
 - A —Reverse aircraft heading or proceed toward an area of known VFR conditions.
 - B —Reduce airspeed to maneuvering speed and maintain a constant altitude.
 - C —Set power for recommended turbulence penetration airspeed and attempt to maintain a level flight attitude.
11. A jet stream is defined as wind of
 - A —30 knots or greater.
 - B —40 knots or greater.
 - C —50 knots or greater.
12. The strength and location of the jet stream is normally
 - A —stronger and farther north in the winter.
 - B —weaker and farther north in the summer.
 - C —stronger and farther north in the summer.

- 13.** (Refer to Exam Figure 1, Page 4-4.) The symbol [2800] on the plan view of the VOR/DME-A procedure at 7D3 represents a minimum safe sector altitude within 25 NM of
- A —DEANI intersection.
 - B —White cloud VORTAC.
 - C —Baldwin Municipal Airport.
- 14.** (Refer to Exam Figure 1, Page 4-4.) What minimum navigation equipment is required to complete the VOR/DME-A procedure?
- A —One VOR receiver.
 - B —One VOR receiver and DME.
 - C —Two VOR receivers and DME.
- 15.** The minimum aircraft radio-navigation equipment needed to perform a NDB approach is
- A —ADF.
 - B —VOR and ADF.
 - C —DME and ADF.
- 16.** (Refer to Exam Figure 2, Page 4-5.)
Category A aircraft
Last assigned altitude 3,000 feet
If cleared for NDB RWY 28 approach (Lancaster/Fairfield) over ZZV VOR, the flight would be expected to
- A —proceed straight in from CRISY to the S-28 minimums of 1620-1.
 - B —proceed to CRISY, then execute the teardrop procedure as depicted on the approach chart.
 - C —proceed direct to CASER, then straight in to S-28 minimums of 1620-1.
- 17.** While being vectored, if crossing the ILS final approach course becomes imminent and an approach clearance has not been issued, what action should be taken by the pilot?
- A —Turn outbound on the final approach course, execute a procedure turn, and inform ATC.
 - B —Turn inbound and execute the missed approach procedure at the outer marker if approach clearance has not been received.
 - C —Maintain the last assigned heading and query ATC.
- 18.** (Refer to Exam Figure 3, Page 4-6.) Using a groundspeed of 90 knots on the ILS final approach course, what rate of descent should be used as a reference to maintain the ILS glide slope?
- A —415 feet per minute.
 - B —480 feet per minute.
 - C —555 feet per minute.
- 19.** (Refer to Exam Figure 4, Page 4-7.) Under which conditions should the missed approach procedure for the RNAV RWY 33 approach be initiated?
- A —Immediately upon reaching the 5.0 DME from the FAF.
 - B —When passage of the MAP waypoint is shown on the ambiguity indicator.
 - C —After the MDA is reached and 1.8 DME fix from the MAP waypoint.
- 20.** If an early missed approach is initiated before reaching the MAP, the following procedure should be used unless otherwise cleared by ATC.
- A —Proceed to the missed approach point at or above the MDA or DH before executing a turning maneuver.
 - B —Begin a climbing turn immediately and follow missed approach procedures.
 - C —Maintain altitude and continue past MAP for 1 minute or 1 mile, whichever occurs first.
- 21.** What are the main differences between a visual approach and a contact approach?
- A —The pilot must request a contact approach; the pilot may be assigned a visual approach and higher weather minimums must exist.
 - B —The pilot must request a visual approach and report having the field in sight; ATC may assign a contact approach, if VFR conditions exist.
 - C —Any time the pilot reports the field in sight, ATC may clear the pilot for a contact approach; for a visual approach, the pilot must advise that the approach can be made under VFR conditions.

- 22.** When may a pilot make a straight-in landing, if using an IAP having only circling minimums?
- A —A straight-in landing may not be made, but the pilot may continue to the runway at MDA and then circle to land on the runway.
 - B —The pilot may land straight-in if the runway is the active runway and he has been cleared to land.
 - C —A straight-in landing may be made if the pilot has the runway in sight in sufficient time to make a normal approach for landing, and has been cleared to land.
- 23.** Assume this clearance is received:
“Cleared for ILS Runway 07 left approach, side-step to runway 07 right.”
When would the pilot be expected to commence the side-step maneuver?
- A —As soon as possible after the runway environment is in sight.
 - B —Any time after becoming aligned with the final approach course of Runway 07 left, and after passing the final approach fix.
 - C —After reaching the circling minimums for Runway 07 right.
- 24.** What does the absence of the procedure turn barb on the planview on an approach chart indicate?
- A —A procedure turn is not authorized.
 - B —Teardrop-type procedure turn is authorized.
 - C —Racetrack-type procedure turn is authorized.
- 25.** (Refer to Exam Figure 5, Page 4-8.) What is the landing minimum if you are cleared for the LOC RWY S-18 approach at Stapleton International?
- A —5,000 RVR.
 - B —300-foot ceiling and 1 mile visibility.
 - C —1 mile visibility.
- 26.** Which fixes on the IAP Charts are initial approach fixes?
- A —Any fix on the enroute facilities ring, the feeder facilities ring, and those at the start of arc approaches.
 - B —Only the fixes at the start of arc approaches and those on either the feeder facilities ring or enroute facilities ring that have a transition course shown to the approach procedure.
 - C —Any fix that is identified by the letters IAF.
- 27.** Where a holding pattern is specified in lieu of a procedure turn, the holding maneuver must be executed within
- A —the 1 minute time limitation or published leg length.
 - B —a radius of 5 miles from the holding fix.
 - C —10 knots of the specified holding speed.
- 28.** You enter a holding pattern at a fix, not the same as the approach fix, and receive an EFC time of 1530. At 1520 you experience complete two-way communications failure. Which procedure should you follow to execute the approach to a landing?
- A —Depart the holding fix to arrive at the approach fix as close as possible to the EFC time and complete the approach.
 - B —Depart the holding fix at the EFC time, and complete the approach.
 - C —Depart the holding fix at the EFC time or earlier if your flight planned ETA is before the EFC.

Orig 88126
VOR/DME-A

AL-6787 (FAA)

BALDWIN MUNI (7D3)
 BALDWIN, MICHIGAN

MINNEAPOLIS CENTER
 132.9 398.9
 CTAF 122.9

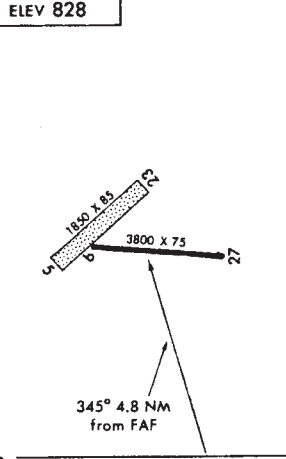
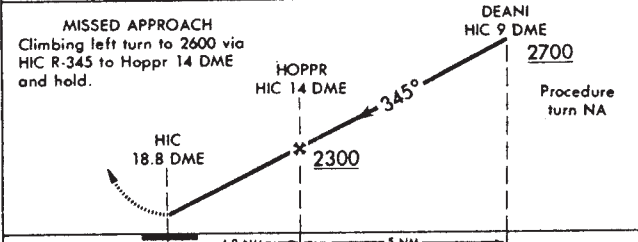
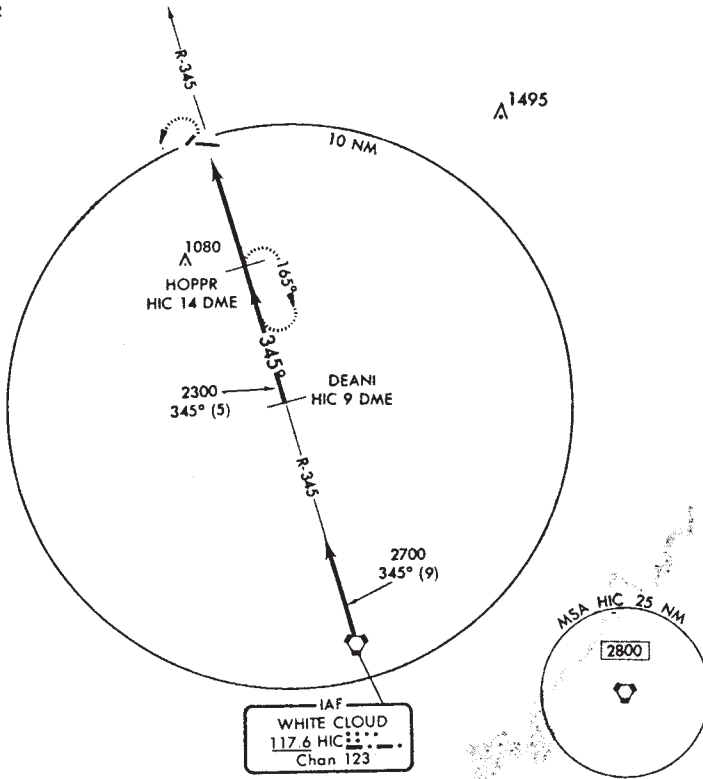

CATEGORY	A	B	C	D
CIRCLING	1540-1 712 (800-1)		1540-2 712 (800-2)	NA

Use Muskegon altimeter setting.
 Procedure not authorized at night.

⚠ NA

Knots	60	90	120	150	180
Min.Sec					

VOR/DME-A

43°53'N-85°50'W

BALDWIN, MICHIGAN
BALDWIN MUNI (7D3)

Exam Figure 1. VOR/DME-A (7D3)

NDB RWY 28

AL-6212 (FAA)

LANCASTER/FAIRFIELD COUNTY (I15)
LANCASTER, OHIO

COLUMBUS APP CON
132.3 279.6
UNICOM 122.8 (CTAF)
CLNC DEL
121.65

APPLETON
116.7 APE
Chan 114

IAF
ZANESVILLE
111.4 ZZV
Chan 51

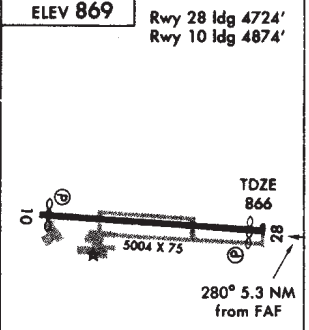
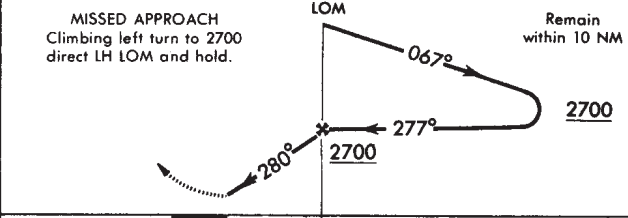
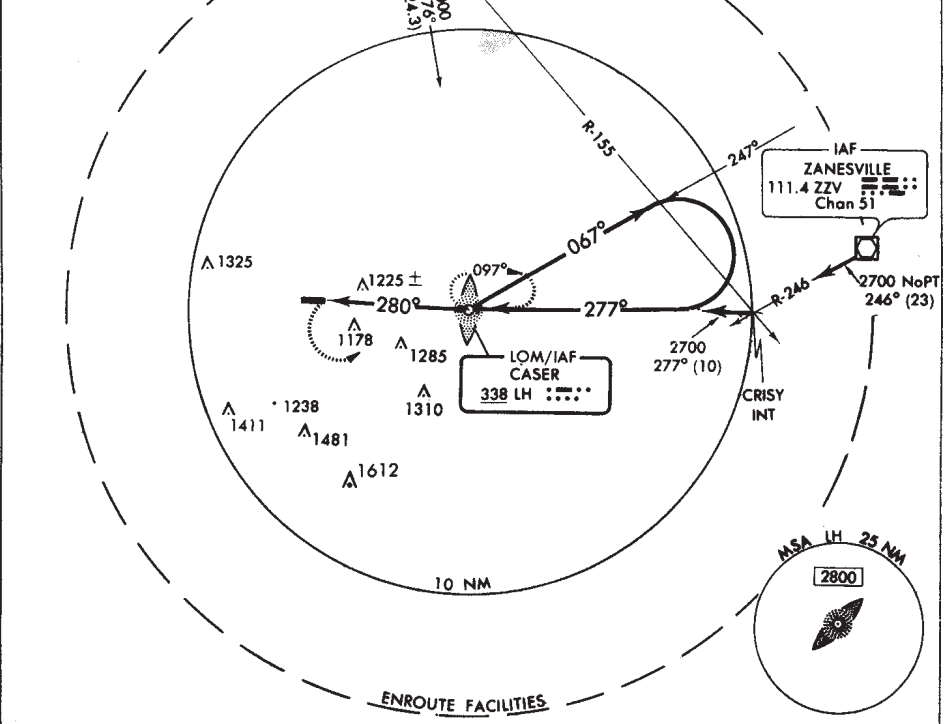

CATEGORY	A	B	C	D
S-28	1620-1 754 (800-1)	1620-1¼ 754 (800-1¼)	1620-2¼ 754 (800-2¼)	1620-2½ 754 (800-2½)
CIRCLING	1620-1 754 (800-1)	1620-1¼ 754 (800-1¼)	1620-2¼ 754 (800-2¼)	1620-2½ 754 (800-2½)

Use Columbus/Rickenbacker altimeter setting.
 ▼
 ▲ NA

REIL Rwys 10 and 28
MIRL Rwy 10-28

FAF to MAP 5.3 NM					
Knots	60	90	120	150	180
Min:Sec	5:18	3:32	2:39	2:07	1:46

NDB RWY 28

39°45'N-82°39'W

LANCASTER, OHIO
LANCASTER/FAIRFIELD COUNTY (I15)

Exam Figure 2. NDB RWY 28, Lancaster/Fairfield County

EUGENE

§ MAHLON SWEET FLD (EUG) 7 NW GMT-8(-7DT) 44°07'19"N 123°13'03"W
 365 B 54 FUEL 100LL JET A OX 1, 2, 3, 4 TPA-1165(800) CFR Index B
 RWY 16-34: H6202X150 (ASPH-PTC) S-155, D-190, DT-300 HIRL
 RWY 16: MALSR RWY 34: ODALS, VASI(V41)—GA 3.0" TCH 54'
 RWY 03-21: H5221X150 (ASPH) S-60, D-68, DT-105 MIRL
 RWY 03: VASI(V41)—GA 3.0" TCH 50.4'. Trees. RWY 21: VASI(V41)—GA 3.0" TCH 53.2'. Trees
AIRPORT REMAINS: Attended continuously, phone 503-687-5431 between 0100-1600Z. CAUTION—migratory waterfowl and other birds in vicinity. ACTIVATE MALSR Rwy 16 and ODALS Rwy 34—118.9, MRL Rwy 03-21 unavailable when twr clsd. CLOSED to unscheduled air carrier operations with more than 30 passenger seats during twr closure except PPR call airport manager 503-687-5430. Taxiways F and G closed to Part 121 ops. Terminal: apron available to scheduled air carriers and flights with prior permission. Control Zone effective continuously.
COMMUNICATIONS: CTAF 118.9 ATIS 125.2 (1400-0800Z) UNICOM 122.95
 PORTLAND FSS (PDX) LC 688-8411. NOTAM FILE EUG
 EUGENE FCO 122.3 122.1R 112.9T (PORTLAND FSS)
 (R) EUGENE APP/DEP COM 119.6 (280°-090°), 120.2 (091°-279°) (1400-0800Z)
 (R) SEATTLE CENTER APP/DEP COM 125.8 (0800-1400Z) GND COM/CLNC DEL 121.7
 EUGENE TOWER 118.9 (1400-0800Z) GND COM/CLNC DEL 121.7
 STAGE II SVC ctc APP COM within 25 NM
 RADIO AIMS TO NAVIGATION: NOTAM FILE EUG
 EUGENE (M) AIRPORTAC 112.9 EUG Chan 76 44°07'16"N 123°13'18"W at fld 360/20E
 General outlook on TWEB 0600-1300Z;
 FRANK NDB (LOM) 260 EU 44°12'47"N 123°13'10"W 179°5.5 NM to fld.
 NDB unusable 190°-270° beyond 11 NM.
 ILS 109.5 EUG RWY 16 LOM FRANK NDB
 ILS unmonitored when tower closed.

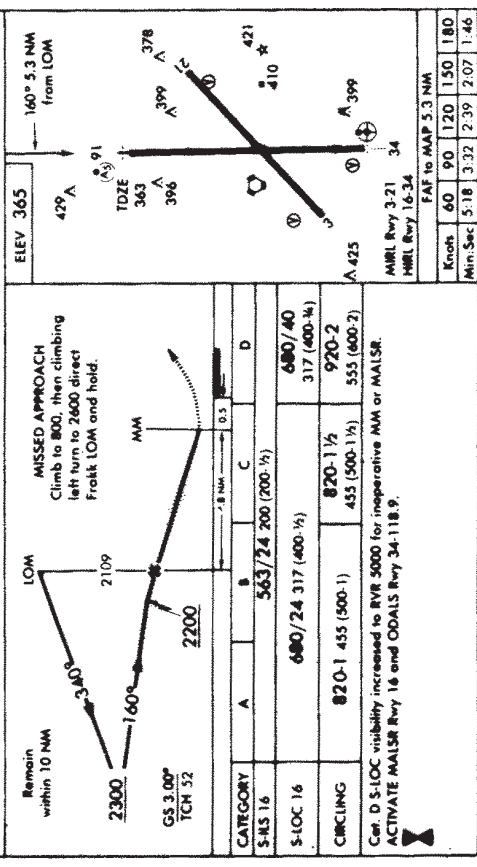
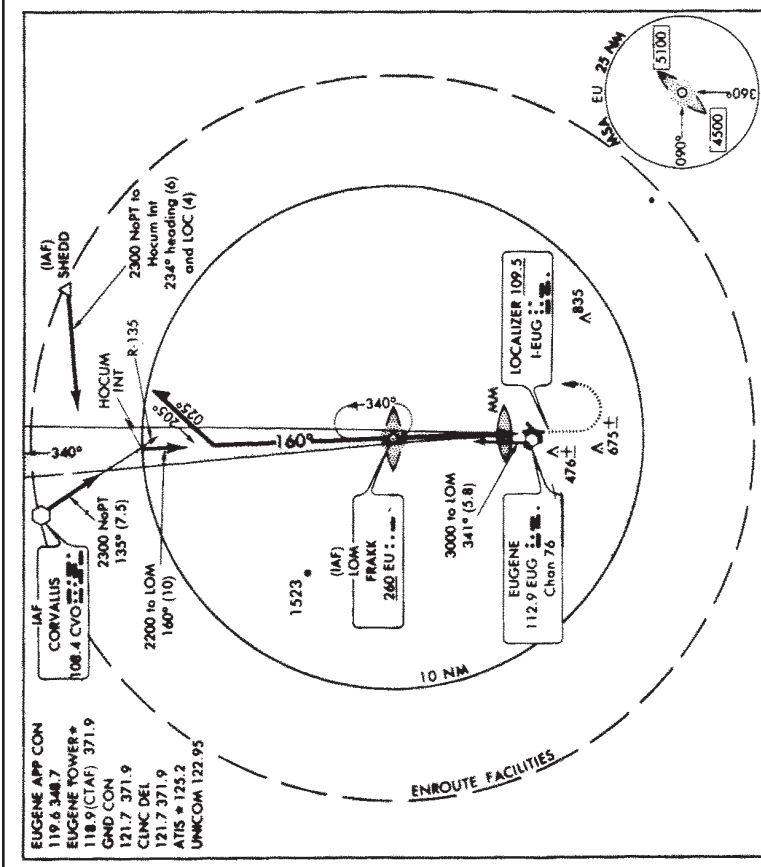

ILS RWY 16 44°07'N-123°13'W
 EUGENE, OREGON
 EUGENE/MAHLON SWEET FIELD (EUG)

Exam Figure 3. ILS RWY 16 (EUG) and excerpt from Airport/Facility Directory

Amdt 1 91150

RNAV RWY 33

AL-768 (FAA)

DALLAS/ADDISON (ADS)
DALLAS, TEXAS

ATIS 123.8
REGIONAL 123.9
ADDISON TOWER 121.1 (CTAF) 239.0
GND CON 121.6
CLNC DEL 119.55
UNICOM 122.95

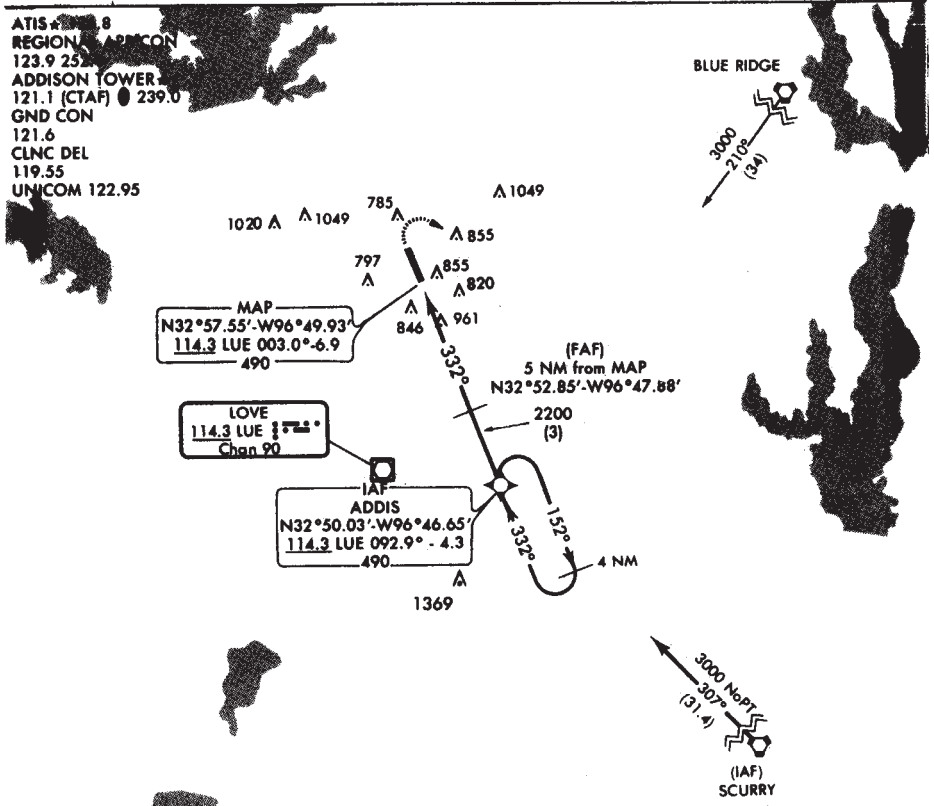

MISSED APPROACH
Climb to 1500 then climbing right turn to 3000 direct ADDIS WPT and hold.

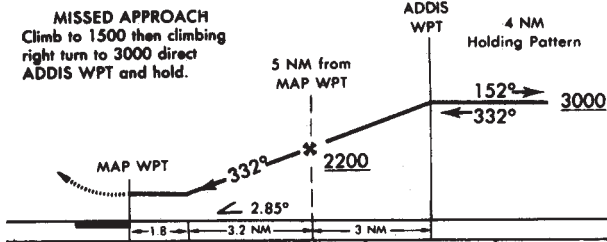

CATEGORY	A	B	C	D
S-33	1220-1 577 (600-1)		1220-1 1/2 577 (600-1 1/2)	1220-1 3/4 577 (600-1 3/4)
CIRCLING	1220-1 577 (600-1)		1220-1 1/2 577 (600-1 1/2)	1260-2 617 (700-2)

When control zone not in effect, use Dallas-Love Field altimeter setting.
ACTIVATE MALS Rwy 15 and REIL Rwy 33-CTAF.



ELEV 643 Rwy 15 ldg 6221'
Rwy 33 ldg 6733'

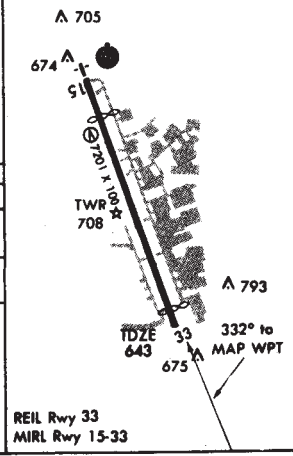

RNAV RWY 33

32°58'N-96°50'W

DALLAS, TEXAS
DALLAS/ADDISON (ADS)

Exam Figure 4. RNAV RWY 33 (ADS)

Amdt 4 91038

LOC RWY 18

DENVER/STAPLETON INTL (DEN)
DENVER, COLORADO

ATIS ARR 125.6
DEP 124.45
DENVER APP CON
NORTH 127.4 288.1
SOUTH 120.8 363.0
DENVER TOWER
118.3 119.5 257.8
GND CON
121.9 257.8
CLNC DEL
127.6 257.8

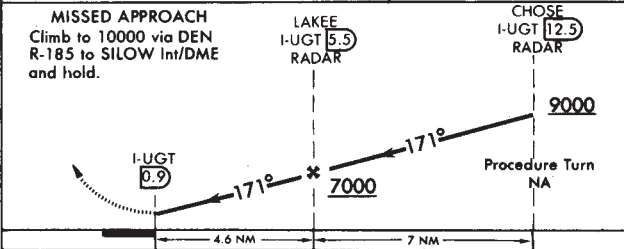
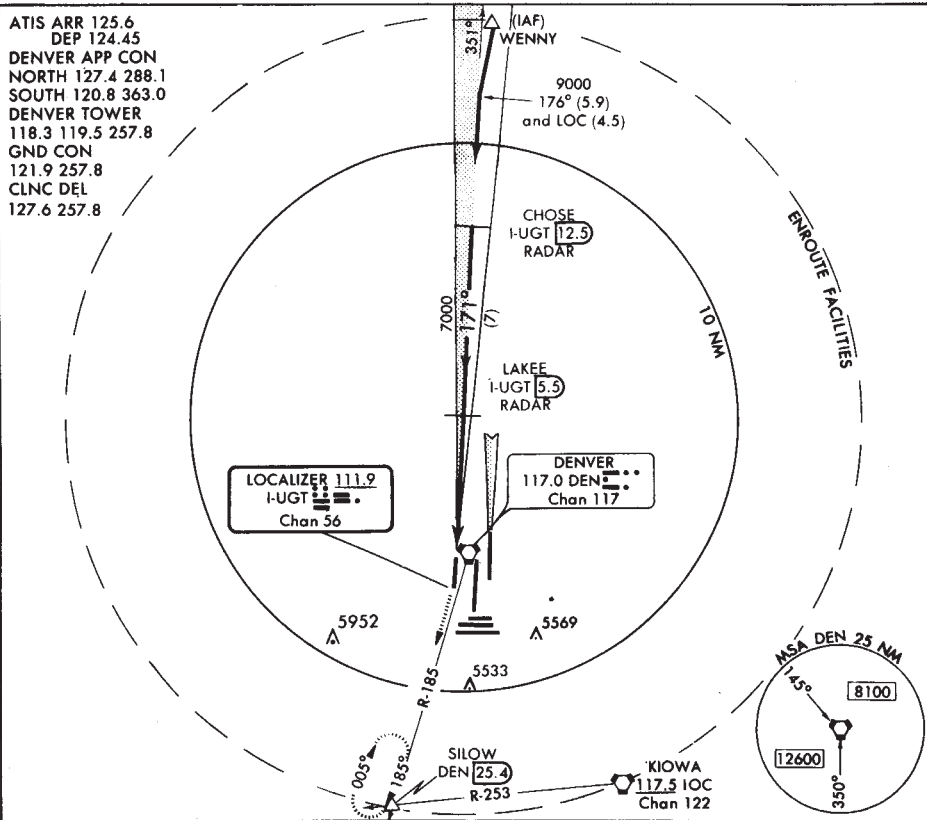

CATEGORY	A	B	C	D
S-18		5560/50	319 (300-1)	
CIRCLING	5860-1 527 (600-1)	5880-1 547 (600-1)	5880-1½ 547 (600-1½)	5900-2 567 (600-2)

Simultaneous approach authorized with Rwy 17L.
Radar or DME required.

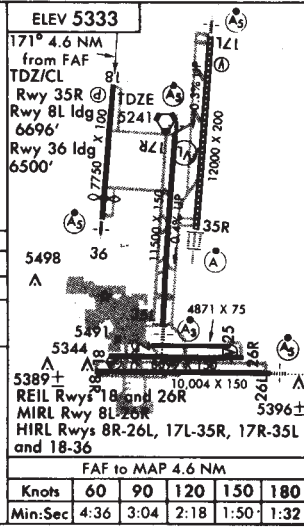

FAF to MAP 4.6 NM					
Knots	60	90	120	150	180
Min:Sec	4:36	3:04	2:18	1:50	1:32

LOC RWY 18

39°46'N-104°53'W

DENVER, COLORADO
DENVER/STAPLETON INTL (DEN)

Exam Figure 5. LOC RWY 8 (DEN)

Stage 5 Exam

En Route & Prep for Checkride Final Exam

Name: _____

Grade: _____ Date: _____

Instructor: _____

Circle the most correct answer choice.

- If you are instructed to descend from your current altitude 16,000 ft MSL to 13,000 ft MSL, you should descend:
A —at 500 fpm throughout.
B —at the optimum rate throughout.
C —at the optimum rate, reducing to 500-1,500 fpm for the last 1,000 feet.
- The VFR-On-Top cruising altitude is based on:
A —true course.
B —magnetic course.
C —magnetic heading.
- What relationship exists between the winds at 2,000 feet above the surface and the surface winds?
A —The winds at 2,000 feet and the surface winds flow in the same direction, but the surface winds are weaker due to friction.
B —The winds at 2,000 feet tend to parallel the isobars while the surface winds cross the isobars at an angle toward lower pressure and are weaker.
C —The surface winds tend to veer to the right of the winds at 2,000 feet and are usually weaker.
- Which weather phenomenon is always associated with the passage of a frontal system?
A —A wind change.
B —An abrupt decrease in pressure.
C —Clouds, either ahead or behind the front.
- What type of clouds will be formed if very stable moist air is forced upslope?
A —First stratified clouds and then vertical clouds.
B —Vertical clouds with increasing height.
C —Stratified clouds with little vertical development.
- Which primary source should be used to obtain forecast weather information at your destination for the planned ETA?
A —Aviation Area Forecast.
B —Radar Summary and Weather Depiction Charts.
C —Terminal Aerodrome Forecast.
- What is the single source reference that contains information regarding frontal movement, turbulence, and icing conditions for a specific area?
A —Terminal Aerodrome Forecast.
B —Weather Depiction Chart.
C —Aviation Area Forecast.
- What is the forecast wind at 1800Z in the following TAF?
KMEM 091640Z 1818 0000KT 1/2SM RA FG OVC005=
A —Calm.
B —Unknown.
C —Not recorded.
- On what frequency should you obtain Enroute Flight Advisory Service below FL 180?
A —122.1T/112.8R.
B —123.6.
C —122.0.
- What minimum weather conditions must be forecast for your ETA at an airport that has a precision approach procedure, with standard alternate minimums, in order to list it as an alternate for the IFR flight?
A —600-foot ceiling and 2 SM visibility at your ETA.
B —600-foot ceiling and 2 SM visibility from 2 hours before to 2 hours after your ETA.
C —800-foot ceiling and 2 SM visibility at your ETA.
- What are the minimum fuel requirements for airplanes in IFR conditions, if the first airport of intended landing is forecast to have a 1,500-foot ceiling and 3 mile visibility at flight-planned ETA? Fuel to fly to the first airport of intended landing,
A —and fly thereafter for 45 minutes at normal cruising speed.
B —fly to the alternate, and fly thereafter for 45 minutes at normal cruising speed.
C —fly to the alternate, and fly thereafter for 30 minutes at normal cruising speed.

- 12.** How much colder than standard temperature is the actual temperature at 9,000 feet, as indicated in the following excerpt from the Winds and Temperature Aloft Forecast?
- | | | |
|----|---------|---------|
| FT | 6000 | 9000 |
| | 0737-04 | 1043-10 |
- A —3°C.
 B —10°C.
 C —7°C.
- 13.** Unsaturated air flowing upslope will cool at the rate of approximately (dry adiabatic lapse rate)
- A —3°C per 1,000 feet.
 B —2°C per 1,000 feet.
 C —2.5°C per 1,000 feet.
- 14.** The station originating the following weather report has a field elevation of 1,300 feet MSL. From the bottom of the overcast cloud layer, what is the thickness? (tops of OVC are reported at 3800 feet)
- SPECI KOKC 2228Z 28024G36KT 3/4SM
 BKN008 OVC020 28/23 A3000
- A —500 feet.
 B —1,700 feet.
 C —2,500 feet.
- 15.** Which meteorological condition is issued in the form of a SIGMET (WS)?
- A —Widespread sand or duststorms lowering visibility to less than 3 miles.
 B —Moderate icing.
 C —Sustained winds of 30 knots or greater at the surface.
- 16.** En route at FL 290, the altimeter is set correctly, but not reset to the local altimeter setting of 30.57" Hg during descent. If the field elevation is 650 feet and the altimeter is functioning properly, what is the approximate indication upon landing?
- A —715 feet.
 B —1,300 feet.
 C —Sea level.
- 17.** What should be the indication on the magnetic compass as you roll into a standard rate turn to the left from a west heading in the Northern hemisphere?
- A —The compass will initially indicate a turn to the right.
 B —The compass will remain on west for a short time, then gradually catch up to the magnetic heading of the aircraft.
 C —The compass will indicate the approximate correct magnetic heading if the roll into the turn is smooth.
- 18.** What instruments are primary for pitch, bank, and power, respectively, when transitioning into a constant airspeed climb from straight-and-level flight?
- A —Attitude indicator, heading indicator, and manifold pressure gauge or tachometer.
 B —Attitude indicator for both pitch and bank; airspeed indicator for power.
 C —Vertical speed, attitude indicator, and manifold pressure or tachometer.
- 19.** What is the correct sequence in which to apply the three skills used in instrument flying?
- A —Aircraft control, cross-check, and instrument interpretation.
 B —Instrument interpretation, cross-check, and aircraft control.
 C —Cross-check, instrument interpretation, and aircraft control.
- 20.** (Refer to Exam Figure 1, Page 5-5.) What is the correct sequence for recovery from the unusual attitude indicated?
- A —Reduce power, increase back elevator pressure, and level the wings.
 B —Reduce power, level the wings, bring pitch attitude to level flight.
 C —Level the wings, raise the nose of the aircraft to level flight attitude, and obtain desired airspeed.
- 21.** An aircraft which is located 30 miles from a VOR station and shows a 1/2-scale deflection on the CDI would be how far from the selected course centerline?
- A —1 1/2 miles.
 B —2 1/2 miles.
 C —3 1/2 miles.

- 22.** Determine the approximate time and distance to a station if a 5° wing-tip bearing change occurs in 1.5 minutes with a true airspeed of 95 knots.
- A —16 minutes and 14.3 NM.
 - B —18 minutes and 28.5 NM.
 - C —18 minutes and 33.0 NM.
- 23.** What indication should a pilot receive when a VOR station is undergoing maintenance and may be considered unreliable?
- A —No coded identification, but possible navigation indications.
 - B —Coded identification, but no navigation indications.
 - C —A voice recording on the VOR frequency announcing that the VOR is out of service for maintenance.
- 24.** The minimum requirements, within the last 6 months, to be current for IFR is
- A —6 instrument approaches, holding procedures, and intercepting and tracking courses through the use of navigation systems, in the appropriate category of aircraft for the instrument privileges sought.
 - B —6 hours in the same category aircraft.
 - C —6 hours in the same category aircraft, and at least 3 of the 6 hours in actual conditions.
- 25.** Which airspace is defined as a transition area when designated in conjunction with an airport which has a prescribed IAP?
- A —The Class E airspace extending upward from 700 feet or more above the surface and terminating at the base of the overlying controlled airspace.
 - B —That Class D airspace extending from the surface and terminating at the base of the continental control area.
 - C —The Class C airspace extending from the surface to 700 or 1,200 feet AGL, where designated.
- 26.** Which procedure is recommended to prevent or overcome spatial disorientation?
- A —Reduce head and eye movements to the extent possible.
 - B —Rely on the kinesthetic sense.
 - C —Rely on the indications of the flight instruments.
- 27.** Before beginning any flight under IFR, the pilot-in-command must become familiar with all available information concerning that flight. In addition, the pilot must
- A —list an alternate airport on the flight plan and become familiar with the instrument approaches to that airport.
 - B —list an alternate airport on the flight plan and confirm adequate takeoff and landing performance at the destination airport.
 - C —be familiar with the runway lengths at airports of intended use, and the alternatives available if the flight cannot be completed.
- 28.** What minimum weather conditions must be forecast for your ETA at an airport that has only a VOR approach with standard alternate minimums, for the airport to be listed as an alternate on the IFR flight plan?
- A —800-foot ceiling and 1 statute mile (SM) visibility.
 - B —800-foot ceiling and 2 SM visibility.
 - C —1,000-foot ceiling and visibility to allow descent from minimum enroute altitude (MEA), approach, and landing under basic VFR.
- 29.** MEA is an altitude which assures
- A —obstacle clearance, accurate navigational signals from more than one VORTAC, and accurate DME mileage.
 - B —a 1,000-foot obstacle clearance within 2 miles of an airway and assures accurate DME mileage.
 - C —acceptable navigational, signal coverage and meets obstruction clearance requirements.
- 30.** What action should you take if your No. 1 VOR receiver malfunctions while operating in controlled airspace under IFR? Your aircraft is equipped with two VOR receivers. The No. 1 receiver has Omni/Localizer/Glide slope capability, and the No. 2 has only Omni.
- A —Report the malfunction immediately to ATC.
 - B —Continue the flight as cleared; no report is required.
 - C —Continue the approach and request a VOR or NDB approach.

- 31.** Which procedure should you follow if you experience two-way communications failure while holding at a holding fix with an EFC time? (The holding fix is not the same as the approach fix.)
- A —Depart the holding fix to arrive at the approach fix as close as possible to the EFC time.
 - B —Depart the holding fix at the EFC time.
 - C —Proceed immediately to the approach fix and hold until EFC.
- 32.** At what point should the timing begin for the first leg outbound in a nonstandard holding pattern?
- A —Abeam the holding fix, or wings level, whichever occurs last.
 - B —When the wings are level at the completion of the 180° turn outbound.
 - C —When abeam the holding fix.
- 33.** (Refer to Exam Figure 2, Page 5-6.) Using an average groundspeed of 90 knots, what constant rate of descent from 2,400 feet MSL at the 6 DME fix would enable the aircraft to arrive at 2,000 feet MSL at the FAF?
- A —200 feet per minute.
 - B —400 feet per minute.
 - C —600 feet per minute.
- 34.** (Refer to Exam Figure 3, Page 5-7.) At which points may you initiate a descent to the next lower minimum altitude when cleared for the VOR RWY 36 approach, from the PUC R-095 IAF (DME operative)?
- A —Start descent from 8,000 when established on final, from 7,500 when at the 4 DME fix, and from 6,180 when landing requirements are met.
 - B —Start descent from 8,000 when established on the PUC R-186, from 6,400 at the 4 DME fix, and from 6,180 when landing requirements are met.
 - C —Start descent from 8,000 at the R-127, from 6,400 at the LR-127, from 6,180 at the 4 DME.
- 35.** If the pilot loses visual reference while circling to land from an instrument approach and ATC radar service is not available, the missed approach action should be to
- A —execute a climbing turn to parallel the published final approach course and climb to the initial approach altitude.
 - B —climb to the published circling minimums then proceed direct to the final approach fix.
 - C —make a climbing turn toward the landing runway and continue the turn until established on the missed approach course.
- 36.** Which of these facilities may be substituted for an MM during a complete ILS IAP?
- A —Surveillance and precision radar.
 - B —Compass locator and precision radar.
 - C —A VOR/DME fix.
- 37.** (Refer to Exam Figure 4, Page 5-8.) What type of entry is recommended for the missed approach holding pattern at Riverside Municipal?
- A —Direct.
 - B —Parallel.
 - C —Teardrop.
- 38.** What conditions are necessary before ATC can authorize a visual approach?
- A —You must have the preceding aircraft in sight, and be able to remain in VFR weather conditions.
 - B —You must have the airport in sight or the preceding aircraft in sight, and be able to proceed to, and land in IFR conditions.
 - C —You must have the airport in sight or a preceding aircraft to be followed, and be able to proceed to the airport in VFR conditions.
- 39.** Which of the following conditions is required before “timed approaches from a holding fix” may be conducted?
- A —If more than one missed approach procedure is available, only one may require a course reversal.
 - B —If more than one missed approach procedure is available, none may require a course reversal.
 - C —Direct communication between the pilot and the tower must be established prior to beginning the approach.
- 40.** When is radar service terminated during a visual approach?
- A —Automatically when ATC instructs the pilot to contact the tower.
 - B —Immediately upon acceptance of the approach by the pilot.
 - C —When ATC advises, “Radar service terminated; resume own navigation.”

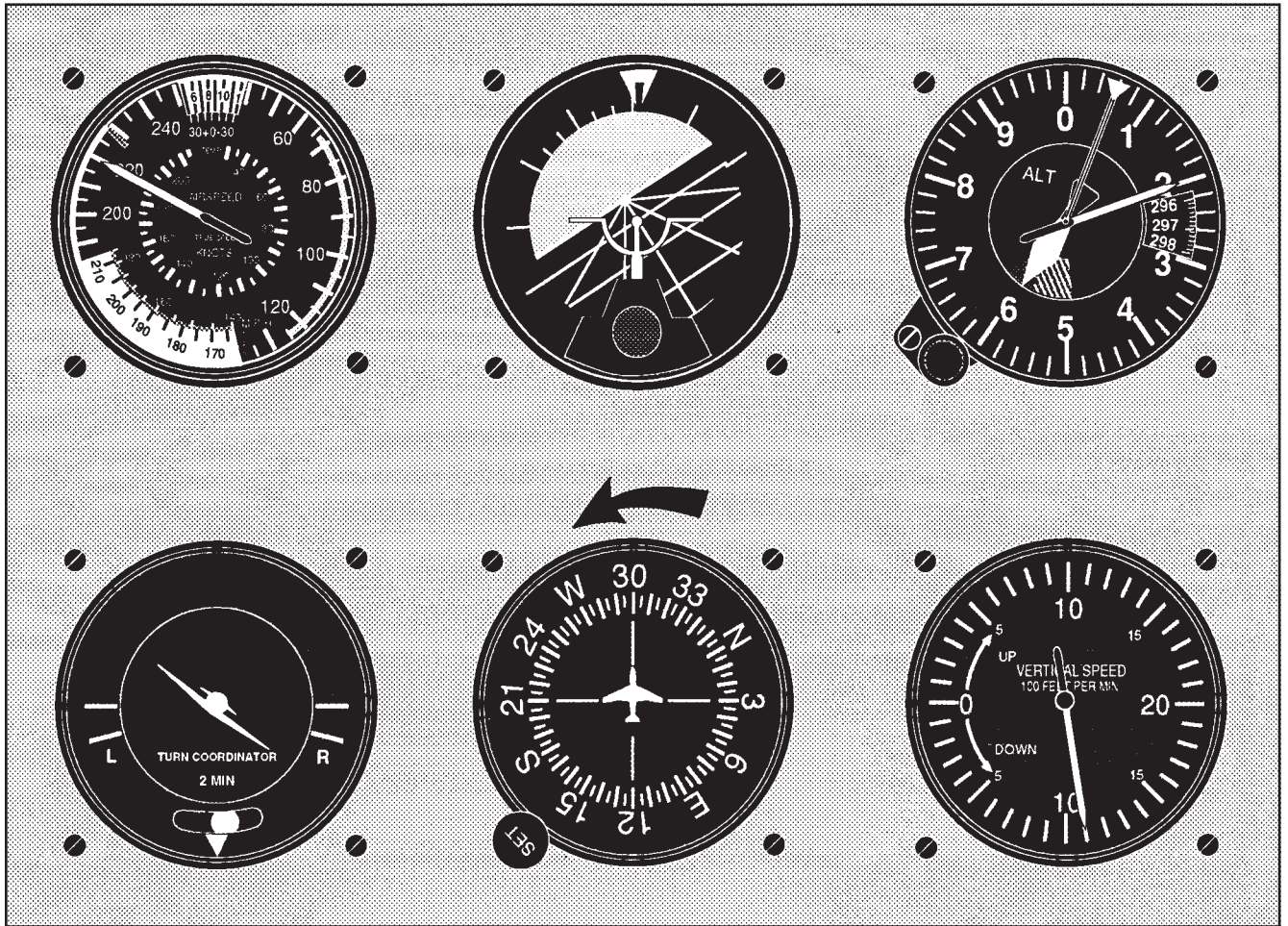

Exam Figure 1. Instrument sequence (unusual attitude)

Amdt 2 91150
VOR/DME-B

AL-858 (FAA)

PASO ROBLES MUNI (PRB)
 PASO ROBLES, CALIFORNIA

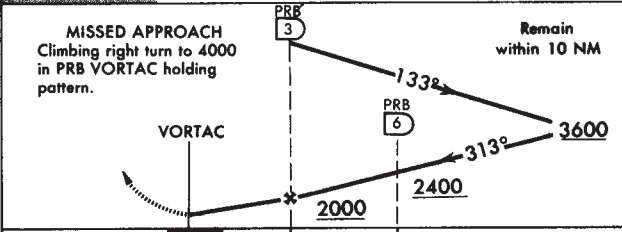
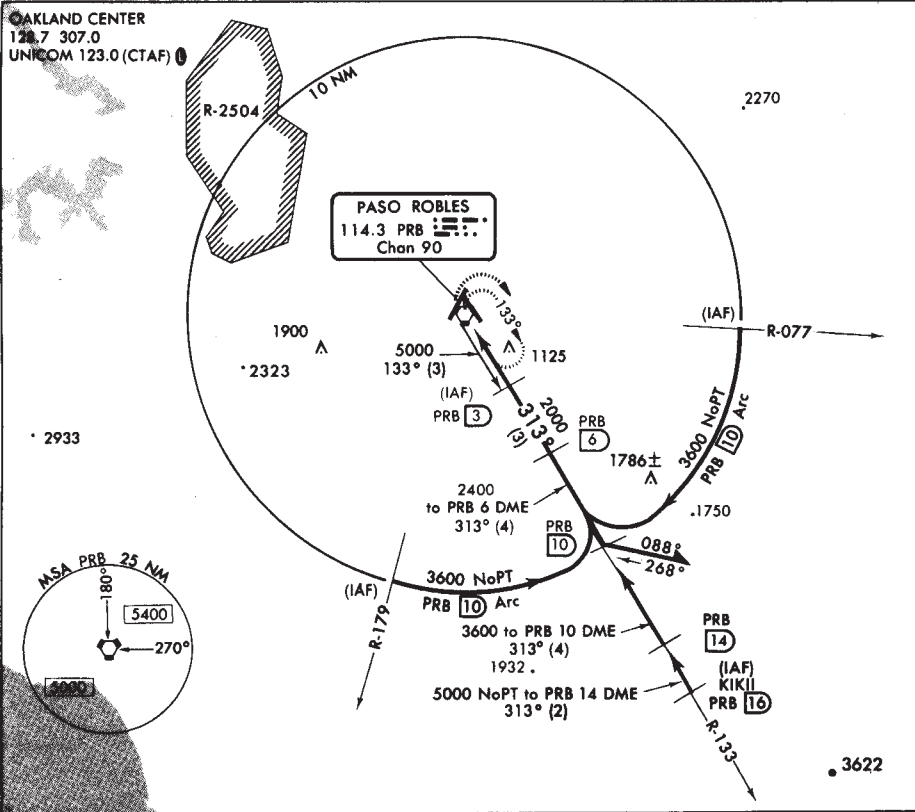

CATEGORY	A	B	C	D
CIRCLING	1440-1 604 (700-1)		1440-1 3/4 604 (700-1 3/4)	1440-2 604 (700-2)

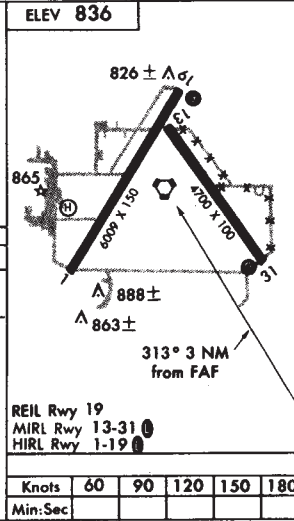

VOR/DME-B

35°40'N - 120°38'W

PASO ROBLES, CALIFORNIA
 PASO ROBLES MUNI (PRB)

Exam Figure 2. VOR/DME-B (PRB)

Orig 89124
VOR RWY 36

AL-681 (FAA)

PRICE/CARBON COUNTY (PUC)
 PRICE, UTAH

SALT LAKE CITY CENTER
 134.8 257.7
 UNICOM 122.8 (CTAF)

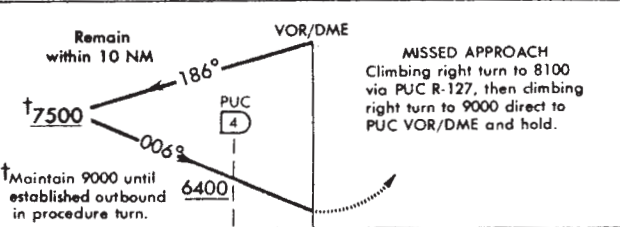
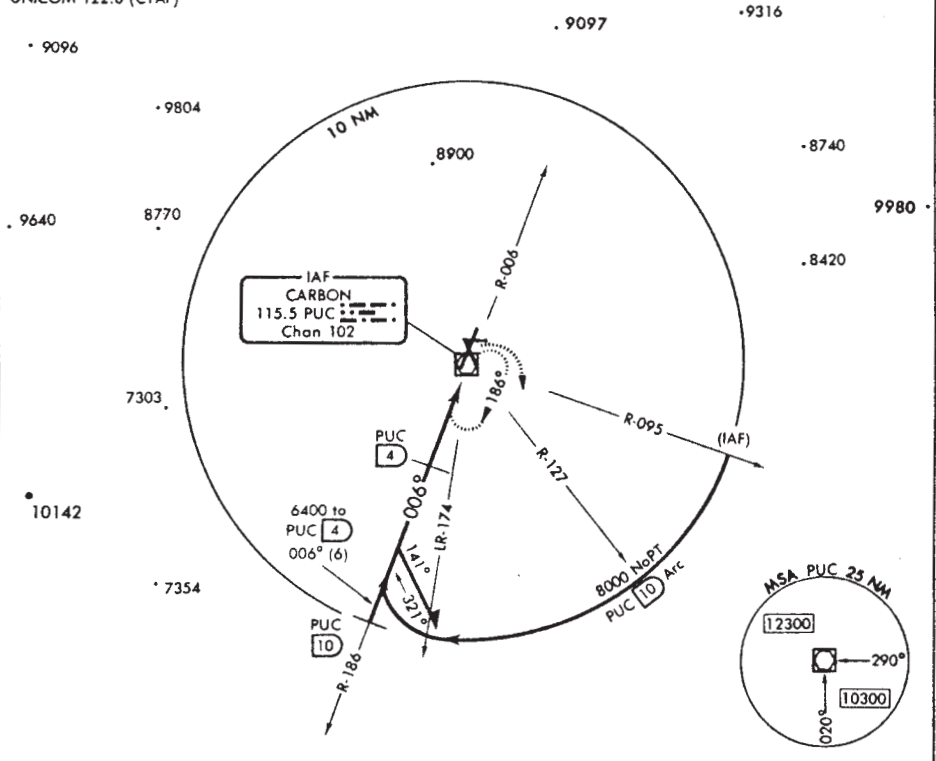

ELEV 5921

Rwy 25 Idg 3412'

MIRL Rwy 14-32 and 18-36

TDZE 5844

006° to PUC VOR/DME

Knots	60	90	120	150	180
Min:Sec					

CATEGORY	A	B	C	D
S-36	6400-1 556 (500-1)		6400-1½ 556 (500-1½)	6400-1¾ 556 (500-1¾)
CIRCLING	6560-1 639 (700-1)	6680-1¼ 759 (800-1¼)	6720-2¼ 799 (800-2¼)	6920-3 999 (1000-3)
DME MINIMA				
S-36	6180-1 336 (300-1)			

When Price altimeter setting not available, procedure not authorized.

▽

△ NA

VOR RWY 36

39°37'N - 110°45'W

PRICE, UTAH
 PRICE/CARBON COUNTY (PUC)

Exam Figure 3. VOR RWY 36 (PUC)

Appendix 6

Basic ATD Syllabus



The following lessons allow Basic ATD technology to integrate with existing methods of aviation instruction and training. This syllabus follows the guidelines established in Advisory Circular 61-126, and can be used to reduce the total flight training hours, otherwise accomplished in an aircraft, needed to meet the requirements for an instrument rating under Part 61 or Part 141. Approved BATDs may be used for not more than 10 hours of time that ordinarily would be acquired in an aircraft, a flight simulator, or flight training device. This syllabus also encourages using BATDs to supplement the ground training and allows for 10 hours of time to replace the traditional classroom instructional techniques.

Instructors are encouraged to challenge students by altering the virtual environment within which the lessons take place. This can be done by changing the weather (adding turbulence, altering the winds, or assigning the ceiling and visibility to the approach minimum conditions) and/or simulating a system or engine failure. These changes can be set to occur randomly or within a specified time frame, allowing the students to learn flight and decision-making skills simultaneously. This method, in conjunction with training to the Practical Test Standards at all times, will encourage a willing suspension of disbelief and maximize the value of BATDs used in a curriculum.

The following Modules may be supplemented using an approved BATD, in lieu of an aircraft for the flight training component, or traditional ground instruction for the ground training component. The following Modules are suggested because the associated tasks and placement within the curriculum lend themselves particularly well to an integrated flight training environment:

BATD Lesson	PM-S-I	Time Logged
1	Stage 1, Module 1: Ground Training	1.0 hour
2	Stage 1, Module 2: Flight Training	1.0 hour
3	Stage 1, Module 3: Ground Training	1.0 hour
4	Stage 1, Module 4: Ground Training	1.0 hour
5	Stage 1, Module 4: Flight Training	1.0 hour
6	Stage 1, Module 5: Ground Training	1.5 hours
7	Stage 2, Module 2: Ground Training	1.0 hour
8	Stage 2, Module 2: Flight Training	1.0 hour
9	Stage 2, Module 3: Ground Training	1.0 hour
10	Stage 2, Module 3: Flight Training	1.0 hour
11	Stage 2, Module 4: Ground Training	1.0 hour
12	Stage 3, Module 1: Ground Training	1.5 hours
13	Stage 3, Module 1: Flight Training	1.5 hours
14	Stage 3, Module 3: Flight Training	1.0 hour
15	Stage 4, Module 1: Flight Training	1.5 hours
16	Stage 4, Module 2: Ground Training	1.0 hour
17	Stage 4, Module 3: Flight Training	1.0 hour
18	Stage 5, Module 4: Flight Training	1.0 hour
Total time logged in BATD:		10.0 hours Ground Training 10.0 hours Flight Training

BATD / Lesson 1

Minimum 141 Requirements: Dual, 1.0 hour BATD

Objective:

For the student to become familiar with BATD features, and develop an understanding of instrument scanning techniques.

Content:

- ___ BATD orientation
 - ___ Physical controls
 - ___ Virtual controls
- ___ Instrument cockpit check
- ___ Instrument scanning technique
 - ___ Selective radial scan
 - ___ Basic T-scan
 - ___ Other scans

Assignment:

Instrument Flying, Chapters 1 and 2

Completion Standards:

The student must successfully complete all review questions following the assigned reading.

BATD / Lesson 2

Minimum 141 Requirements: Dual, 1.0 hour BATD

Objective:

For the student to become proficient in flight by reference to instruments while maintaining changes of airspeed, and constant airspeed climbs and descents.

Content:

- ___ Instrument scan
- ___ Straight-and-level flight
- ___ Standard rate turns
- ___ Review effects of change of airspeed
- ___ Constant airspeed climbs and descents
- ___ Pattern B
- ___ Pattern D
- ___ Pattern F
- ___ Review ground tracks

Assignment:

Instrument Flying, Chapters 3 and 4

Completion Standards:

The student must effectively control the airplane within 200 feet, 20 degrees, and 20 knots; perform standard rate turns; and successfully complete all review questions following the assigned reading.

BATD / Lesson 3

Minimum 141 Requirements: Dual, 1.0 hour BATD

Objective:

For the student to gain understanding of the straight climb and descent, and turns, during instrument flight.

Content:

- ___ The straight climb
 - ___ Climbing at different airspeeds
 - ___ Variations on entering the climb
 - ___ Climbing at a particular rate
- ___ The straight descent
 - ___ Climbing away from a descent
 - ___ Descending at a particular rate
 - ___ The precision approach
- ___ Turning
 - ___ Bank angle and rate of turn
 - ___ Roll-in and roll-out rate
 - ___ The medium level turn
 - ___ Instrument turns to a specific heading
 - ___ Climbing turns
 - ___ Descending turns
 - ___ Steep level turn
 - ___ Steep climbing turn
 - ___ Steep descending turn
- ___ Pattern A
- ___ Pattern G
- ___ Review ground tracks

Assignment:

Instrument Flying, Chapters 5 and 6

Completion Standards:

The student must successfully complete all review questions following the assigned reading, and effectively control the airplane within 200 feet, 20 degrees, and 20 knots, keeping all turns coordinated.

BATD / Lesson 4

Minimum 141 Requirements: Dual, 1.0 hour BATD

Objective:

For the student to understand how to recognize and recover from unusual attitudes.

Content:

- ___ Unusual attitudes
 - ___ Recognizing an unusual attitude
 - ___ Nose-low attitudes with increasing airspeed
 - ___ Nose-high attitude with decreasing airspeed
 - ___ Nose-high, and approaching the stall
- ___ Pattern D
- ___ Review ground tracks

Assignment:

Instrument Flying, Chapter 7

Completion Standards:

The student must successfully complete all review questions following the assigned reading; effectively control the airplane within 200 feet, 20 degrees, and 20 knots; and recover from unusual attitudes in a timely manner.

BATD / Lesson 5

Minimum 141 Requirements: Dual, 1.0 hour BATD

Objective:

For the student to become proficient at performing timed turns to magnetic compass headings, and at constant-rate climbs and descents, flying solely by reference to instruments.

Content:

- ___ Standard rate turns
- ___ Steep turns
- ___ Time turns to magnetic compass headings
- ___ Pattern A
- ___ Pattern C
- ___ Review ground tracks

Assignment:

Instrument Flying, Chapter 8

Completion Standards:

This lesson is complete when the student can maintain flight within 150 feet, 15 degrees, and 15 knots, and successfully complete all review questions following the assigned reading.

BATD / Lesson 6

Minimum 141 Requirements: Dual, 1.5 hour BATD

Objective:

For the student to gain understanding of normal instrument flight on a partial panel, and continue performing instrument flight training patterns.

Content:

- ___ System failures
 - ___ Loss of heading and/or attitude indicators
- ___ Interpreting pitch attitude on a partial panel
- ___ Interpreting bank attitude on a partial panel
- ___ Straight-and-level flight on a partial panel
- ___ Climbing on a partial panel
- ___ Descending on a partial panel
- ___ Turning on a partial panel
- ___ Recovery from unusual attitudes on a partial panel
- ___ Seven Ts
- ___ Performance sheet
- ___ Pattern D
- ___ Pattern E
- ___ Review ground tracks

Assignment:

Instrument Flying, Chapters 9 and 10

Completion Standards:

The student must successfully complete all review questions following the assigned reading, and maintain flight within 150 feet, 15 degrees, and 15 knots, keeping all turns coordinated.

BATD / Lesson 7

Minimum 141 Requirements: Dual, 1.0 hour BATD

Objective:

For the student to gain operational understanding of DME and the VOR.

Content:

DME

- ___ DME measures slant distance
- ___ DME uses the principle of secondary radar
- ___ DME frequencies
- ___ VOR/DME pairing
- ___ ILS/DME pairing
- ___ DME arcs

VOR

- ___ VOR radial
- ___ How the VOR works
- ___ The range of a VOR
- ___ VORs on aeronautical charts
- ___ VOR/DME, TACAN, VORTAC
- ___ VOR cockpit instrument
- ___ TO or FROM
- ___ Preparing the OBI for use
- ___ Orientation using the VOR
- ___ Tracking using the VOR
- ___ Intercepting a course using the VOR
- ___ The VOR instrument approach
- ___ Pattern J
- ___ Review ground tracks

Assignment:

Instrument Flying, Chapter 14

Completion Standards:

The student must successfully complete all review questions following the assigned reading, and maintain flight within 150 feet, 15 degrees, and 15 knots, keeping all turns coordinated.

BATD / Lesson 8

Minimum 141 Requirements: Dual, 1.0 hour BATD

Objective:

For the student to become proficient at VOR navigation, and at intercepting and tracking VOR/VORTAC radials and DME arcs.

Content:

- ___ VOR/VOT accuracy checks
- ___ VOR navigation techniques
- ___ Homing a VOR radial
- ___ Intercepting and tracking VOR/VORTAC radials
- ___ DME arcs
- ___ VOR full approach
- ___ Pattern H
- ___ Review ground tracks

Assignment:

Instrument Flying, Chapter 12

Completion Standards:

The student must navigate using VORs, and intercept and track VOR/VORTAC radials and DME arcs. Flight should be maintained within 150 feet altitude, 15 knots airspeed, and 15 degrees heading, and the student must successfully complete all review questions following the assigned reading.

BATD / Lesson 9

Minimum 141 Requirements: Dual, 1.0 hour BATD

Objective:

For the student to gain operational understanding of the NDB and ADF, the relative bearing indicator (RBI), the radio magnetic indicator (RMI), and the rotatable-card ADF.

Content:

- ___ The NDB and ADF
 - ___ The Automatic Direction Finder
 - ___ The ADF Cockpit Display
- ___ The Relative Bearing Indicator (RBI)
 - ___ Operational use of the RBI
 - ___ Tracking
 - ___ The NDB approach
- ___ The Radio Magnetic Indicator (RMI) and Rotatable-card ADF
 - ___ Orientation using the RMI
 - ___ The initial interception of course
 - ___ Maintaining course
- ___ Review ground tracks

Assignment:

Instrument Flying, Chapter 11

Completion Standards:

The student must successfully complete all review questions following the assigned reading, and maintain coordinated flight within 150 feet, 15 degrees, and 15 knots.

BATD / Lesson 10

Minimum 141 Requirements: Dual, 1.0 hour BATD

Objective:

For the student to become familiar with radar, RNAV, and VHF direction finding, and become proficient with NDB navigation and intercepting and tracking NDB bearings.

Content:

- ___ ADF orientation
- ___ NDB navigation
- ___ Homing with an NDB
- ___ Tracking with an NDB
- ___ Intercepting NDB bearings
- ___ NDB full approach
- ___ Radar
- ___ RNAV
- ___ VHF direction finding
- ___ Review ground tracks

Assignment:

Instrument Flying, Chapters 10 and 15

Completion Standards:

The student must navigate using the NDB, and intercept and track NDB bearings. Flight should be maintained within 150 feet altitude, 15 knots airspeed, and 15 degrees heading, and the student must successfully complete all review questions following the assigned reading.

BATD / Lesson 11

Minimum 141 Requirements: Dual, 1.0 hour BATD

Objective:

For the student to gain operational understanding of the Instrument Landing System (ILS).

Content:

- ___ Flying the localizer
- ___ Flying the localizer with an HSI
- ___ Flying the localizer backcourse
- ___ Flying the glide slope
- ___ Marker beacons
- ___ Approach lights
- ___ Precision instrument runway markings
- ___ Inoperative ILS components
- ___ ILS full approach
- ___ Simultaneous approaches
- ___ Wind shear on the approach
- ___ Pattern I
- ___ Review ground tracks

Assignment:

Instrument Flying, Chapter 13

Completion Standards:

The student must successfully complete all review questions following the assigned reading, and maintain coordinated flight within 150 feet, 15 degrees, and 15 knots.

BATD / Lesson 12

Minimum 141 Requirements: Dual, 1.5 hour BATD

Objective:

For the student to gain understanding of holding patterns, procedure turns, and DME arcs.

Content:

- ___ Holding patterns
 - ___ Tracking
 - ___ Corrections for wind
 - ___ Entering a holding pattern
 - ___ Holding speeds
- ___ Procedure turns
 - ___ The 45/180 degree procedure turn
 - ___ The 80/260 degree procedure turn
 - ___ The base or teardrop turn
 - ___ Positioning in a racetrack pattern
- ___ DME arcs
- ___ Pattern H
- ___ Review ground tracks

Assignment:

Instrument Flying, Chapter 28

Completion Standards:

The student must successfully complete all review questions following the assigned reading, and maintain coordinated flight within 150 feet, 15 degrees, and 15 knots.

BATD / Lesson 13

Minimum 141 Requirements: Dual, 1.5 hour BATD

Objective:

For the student to become proficient with entries to holds, and holding at VORs.

Content:

- ___ Holding instructions
- ___ Perform 3 holds at a VOR
 - ___ Direct entry, standard turns
 - ___ Parallel entry, nonstandard turns
 - ___ Teardrop entry, standard turns
- ___ VOR approach, radar vectors
- ___ Review ground tracks

Assignment:

Instrument Flying, Chapter 27

Completion Standards:

The student must understand entries to holds, and perform a hold using a VOR. The student should maintain altitude within 150 feet, airspeed within 15 knots, and heading within 15 degrees, and complete all review questions following the assigned reading.

BATD / Lesson 14

Minimum 141 Requirements: Dual, 1.0 hour BATD

Objective:

For the student to become proficient in performing holds at an NDB.

Content:

- ___ Perform NDB hold, standard and nonstandard turns
- ___ Perform NDB hold, partial panel
- ___ Review VOR holding procedures
- ___ Intersection holding
- ___ NDB full approach
- ___ Review ground tracks

Assignment:

Instrument Flying, Chapter 28

Completion Standards:

The student must perform holds at an NDB using the correct entry and timing procedures, and maintain orientation at all times. The student must maintain altitude within 150 feet, airspeed within 15 knots, and heading within 15 degrees, and complete all review questions following the assigned reading.

BATD / Lesson 15

Minimum 141 Requirements: Dual, 1.5 hour BATD

Objective:

For the student to become proficient in performing VOR approaches—full, radar vectors, straight-in and missed approach techniques.

Content:

- ___ Full VOR approach
- ___ VOR missed approach
- ___ Radar vectors VOR approach, using straight-in minimums
- ___ Partial panel VOR radar vectors approach
- ___ Partial panel VOR missed approach
- ___ Review ground tracks

Assignment:

Instrument Flying, Chapter 29

Completion Standards:

The student must perform VOR approaches (full, radar vectors, straight-in, missed approach) within 100 feet of altitude, and 3 dots of the CDI needle. The student must comply with ATC/instructor clearances, perform all procedures according to the approach plates, and successfully complete all review questions following the assigned reading.

BATD / Lesson 16

Minimum 141 Requirements: Dual, 1.0 hour BATD

Objective:

For the student to become proficient in performing NDB approaches, demonstrating full, radar vectors, straight-in, and missed approach techniques, and be introduced to instrument departure procedures.

Content:

- ___ DPs
- ___ NDB full approach
- ___ NDB missed approach
- ___ NDB radar vector approach, using straight-in minimums
- ___ NDB partial panel, radar vector approach
- ___ NDB partial panel missed approach
- ___ Review ground tracks

Assignment:

Instrument Flying, Chapter 26

Completion Standards:

The student must perform NDB full, radar vectors, missed, and straight-in approaches while maintaining flight within 100 feet above minimum descent altitude, not descending lower until a decision to land has been made. The student must maintain the flight within 10 degrees of the runway at the missed approach point. Student should complete all review questions following the assigned reading.

BATD / Lesson 17

Minimum 141 Requirements: Dual, 1.0 hour BATD

Objective:

For the student to become proficient in performing ILS and localizer approaches, including missed approach, full and radar vector techniques.

Content:

- ___ ILS full approach
- ___ ILS missed approach
- ___ ILS radar vector approach, using straight-in minimums
- ___ Localizer radar vector approach
- ___ Localizer back course full approach
- ___ Localizer missed approach
- ___ Review ground tracks

Assignment:

Instrument Flying, Chapter 25

Completion Standards:

The student must perform ILS full and radar vector approaches, and localizer approaches without descending below the minimum altitudes; maintain airspeed within 10 knots of approach speed; and arrive at the MDA prior to the MAP and perform a prompt missed approach at the accurate time. ILS approach must maintain glide slope within less than full needle deflection, and student must complete all review questions following the assigned reading.

BATD / Lesson 18

Minimum 141 Requirements: Dual, 1.0 hour BATD

Objective:

For the student to practice instrument procedures in preparation for the checkride.

Content:

- ___ Departure procedures
- ___ Navigation to airway
- ___ Steep turns
- ___ Recovery from unusual attitudes
- ___ VOR holding
- ___ ADF holding (partial panel)
- ___ Systems and equipment malfunctions
- ___ VOR full approach (partial panel)
- ___ NDB full approach
- ___ Missed approach procedures
- ___ ILS radar vectors approach
- ___ Review ground tracks

Assignment:

Instrument Practical Test Standards

Completion Standards:

The student must perform all instrument procedures within Practical Test Standards and within specified minimums.

Notes

The Pilot's Manual

Instrument Rating Syllabus

This syllabus presents the most integrated and comprehensive flight training program available, along with many advantages:

- Based on *The Pilot's Manual Series*. Schools, instructors, or students can **choose** to supplement the program with other texts, DVDs, etc. This allows freedom to teach or learn the material in the most effective way—on an individual basis.
- All Part 141 requirements have been met in a logical and user-friendly manner.
- Flight lessons are presented side-by-side with their coordinating ground lessons. This integrated approach provides the most efficient path to completion, and is easier to follow than separate ground and flight training programs.
- A complete Basic Aviation Training Device (ATD) syllabus details how to integrate a Basic ATD into your curriculum, supplementing your current training methods for a more efficient training program.
- Flexible enough to be effective for all programs.
- Includes “Optional Reviews” in each stage—allowing the student to review material when necessary, yet still follow the syllabus and maintain progress.
- Every syllabus in the series includes:
 - Instructor endorsements
 - Stage exams
 - Airman Certificate Rating Application and checkride checklist

Curriculums available for *The Pilot's Manual Series*:

Private Pilot Syllabus (#ASA-PM-S-P)

Instrument Rating Syllabus (#ASA-PM-S-I)

Commercial Pilot Syllabus (#ASA-PM-S-C)

Aviation Supplies & Academics, Inc.

7005 132nd Place SE

Newcastle, Washington 98059

www.asa2fly.com



P N R A S A - P M - S - I 4

ISBN 978-1-56027-886-3



9 781560 278863



5 1 2 9 5